

TS CR Industrial Pump Seal

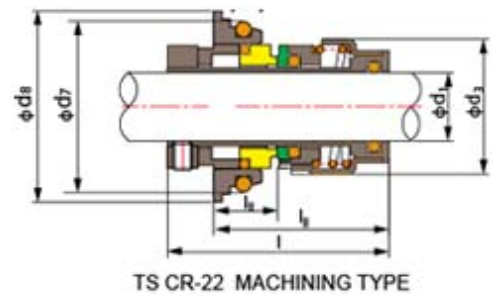
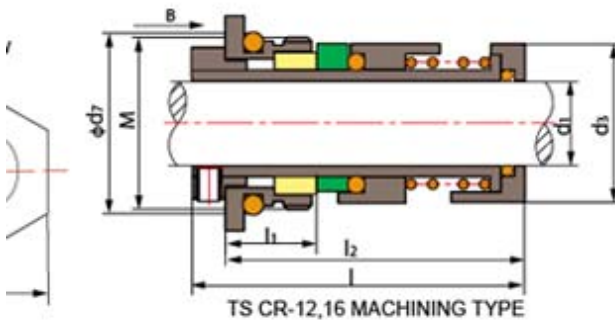
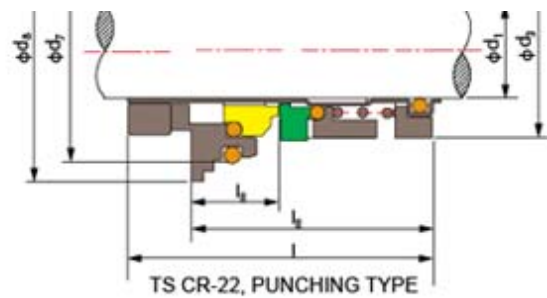
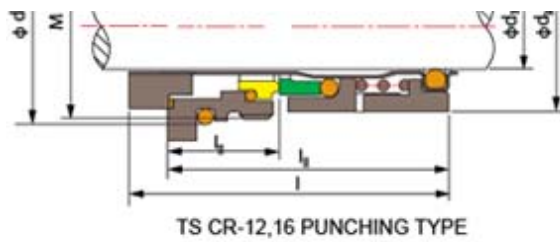

Operating Limits:

Pressure: $\leq 1.0\text{MPa}$

Speed: $\leq 10\text{m/s}$

Temperature: $-30^{\circ}\text{C}\sim+180^{\circ}\text{C}$

Shanghai Trisun Parts Manufacture Co.,Ltd.

Head office in Shanghai:

Room 05-06, 16th Floor, Hongjia Building, No.388 Fushan Rd. (Near Xiangcheng Rd.), Pudong, Shanghai, China.

Post Code: 200122

Tel: +86-21-58355541,+86-21-58353145,+86-21-58353343

Fax: +86-21-58353141

E-mail: trisunseal@yahoo.com.cn



- 1.Rotary Ring (SiC/TC)
- 2.Stationary Ring (SiC/TC)
- 3.Secondary Seal (NBR/VITON)
- 4.Spring &Other Parts (SUS304/SUS316)

Model	d ₁	d ₃	d ₇	d ₈	M	l	l ₁	l ₂	S
CR-12	12	25.0	29	\	M28×1.5	55	19	29.0	35.8
CR-16	16	30.5	34	\	M33×1.5	57.5	20	30.5	40.8
CR-22 PUNCH	22	39	50	59	\	70.0	20	55.0	\
CR-22 MACHINING	22	42	50	60	\	70.0	20	55.0	\

Shanghai Trisun Parts Manufacture Co.,Ltd.

Head office in Shanghai:

Room 05-06, 16th Floor, Hongjia Building, No.388 Fushan Rd. (Near Xiangcheng Rd.), Pudong, Shanghai, China.

Post Code: 200122

Tel: +86-21-58355541,+86-21-58353145,+86-21-58353343

Fax: +86-21-58353141

E-mail: trisunseal@yahoo.com.cn