

TS ST 11/8"-25/8"(inches) Component Seal

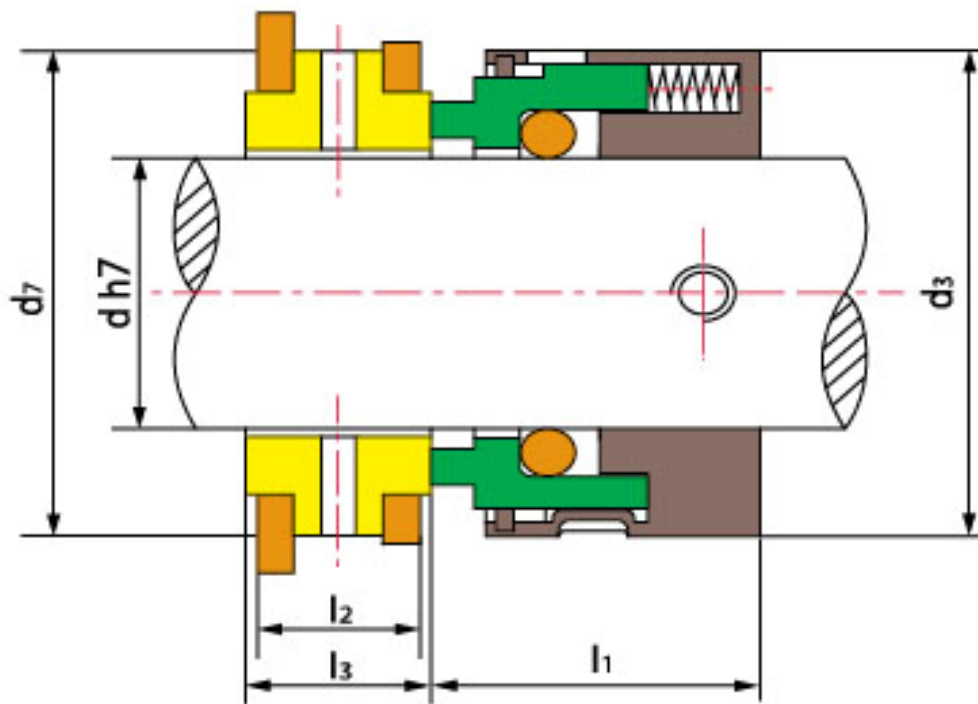

Rotary Ring (Carbon/SiC/TC)

Stationary Ring (SiC/TC)

Shanghai Trisun Parts Manufacture Co.,Ltd.

Head office in Shanghai:

Room 05-06, 16th Floor, Hongjia Building, No.388 Fushan Rd. (Near Xiangcheng Rd.), Pudong, Shanghai, China.

Post Code: 200122

Tel: +86-21-58355541,+86-21-58353145,+86-21-58353343

Fax: +86-21-58353141

E-mail: trisunseal@yahoo.com.cn



Secondary Seal (NBR/VITON)
Spring & Other Parts (SUS304/SUS316)

Operating Limits

Pressure: $\leq 1.2\text{MPa}$

Speed: $\leq 20\text{m/s}$

Temperature: $-30^{\circ}\text{C} \sim +200^{\circ}\text{C}$

Seal size (inches)	d	d ₃	d ₇	l ₁	l ₂	l ₃
1 1/8"	28.575	47.6	59.4	25.6	15.9	25.3
1 5/8"	41.275	62	71.8	29.5	15.9	25.3
2 1/8"	53.975	79.4	84.6	29.3	15.9	25.3
2 5/8"	66.675	88.9	111	41.3	15.9	25.3

Shanghai Trisun Parts Manufacture Co.,Ltd.

Head office in Shanghai:

Room 05-06, 16th Floor, Hongjia Building, No.388 Fushan Rd. (Near Xiangcheng Rd.), Pudong, Shanghai, China.

Post Code: 200122

Tel: +86-21-58355541,+86-21-58353145,+86-21-58353343

Fax: +86-21-58353141

E-mail: trisunseal@yahoo.com.cn