

TSDGS-J01 25mm-100mm Dry Gas Seal

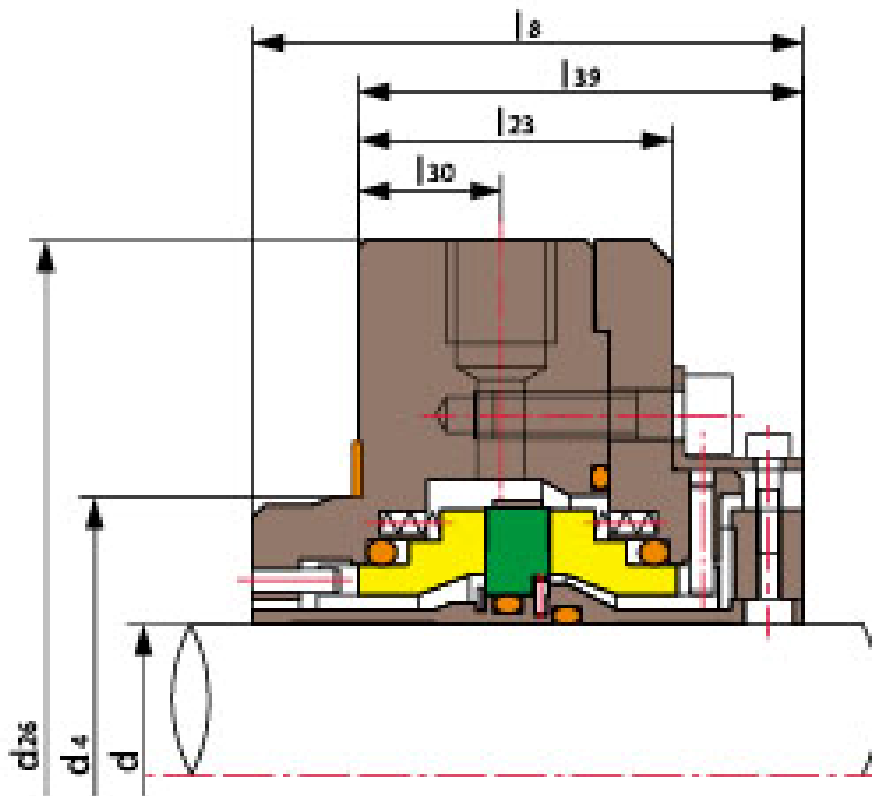

Shanghai Trisun Parts Manufacture Co.,Ltd.

Head office in Shanghai:

Room 05-06, 16th Floor, Hongjia Building, No.388 Fushan Rd. (Near Xiangcheng Rd.), Pudong, Shanghai, China.

Post Code: 200122

Tel: +86-21-58355541,+86-21-58353145,+86-21-58353343

Fax: +86-21-58353141

E-mail: trisunseal@yahoo.com.cn



Rotary Ring (SiC/TC)

Stationary Ring (Carbon)

Secondary Seal (VITON/Encapsulated Ring/PTFE/EPDM/Kalrez)

Other Parts (SUS304/SUS316)

Operating Limits

Pressure: $\leq 1.6\text{MPa}$

Speed: $\leq 25\text{m/s}$

Temperature: $-20^{\circ}\text{C}\sim+260^{\circ}\text{C}$

d	d ₄	d ₂₆	d ₂₈	d ₉₅	l ₈	l ₂₃	l ₃₀	l ₃₉
(mm)	min							
25	41	114	12	64.7	67.8	37.5	15.5	54.5
28	44	117	12	67.7	67.8	37.5	15.5	54.5
30	46	119	12	69.7	67.8	37.5	15.5	54.5
33	49	122	14	72.7	67.8	37.5	15.5	54.5
35	51	124	14	74.7	67.8	37.5	15.5	54.5
38	58	135	14	79.7	69.4	39.8	17.7	56.5
40	60	137	14	81.7	69.4	39.8	17.7	56.5
43	63	140	14	84.7	69.4	39.8	17.7	56.5
45	65	142	14	86.7	69.4	39.8	17.7	56.5
50	70	147	18	91.7	69.4	41.8	17.7	56.5
53	73	150	18	94.7	69.4	41.8	17.7	56.5
55	75	152	18	96.7	69.4	41.8	17.7	56.5
60	85	157	18	101.7	69.4	41.8	17.7	56.5
65	90	180	18	106.7	71.4	43.8	19.7	58.5
80	109	195	18	121.7	71.4	43.8	19.7	58.5
100	129	215	22	141.7	71.4	43.8	19.7	58.5

Shanghai Trisun Parts Manufacture Co.,Ltd.

Head office in Shanghai:

Room 05-06, 16th Floor, Hongjia Building, No.388 Fushan Rd. (Near Xiangcheng Rd.), Pudong, Shanghai, China.

Post Code: 200122

Tel: +86-21-58355541,+86-21-58353145,+86-21-58353343

Fax: +86-21-58353141

E-mail: trisunseal@yahoo.com.cn