

## TSDGS-J02 56mm-257mm Dry Gas Seal

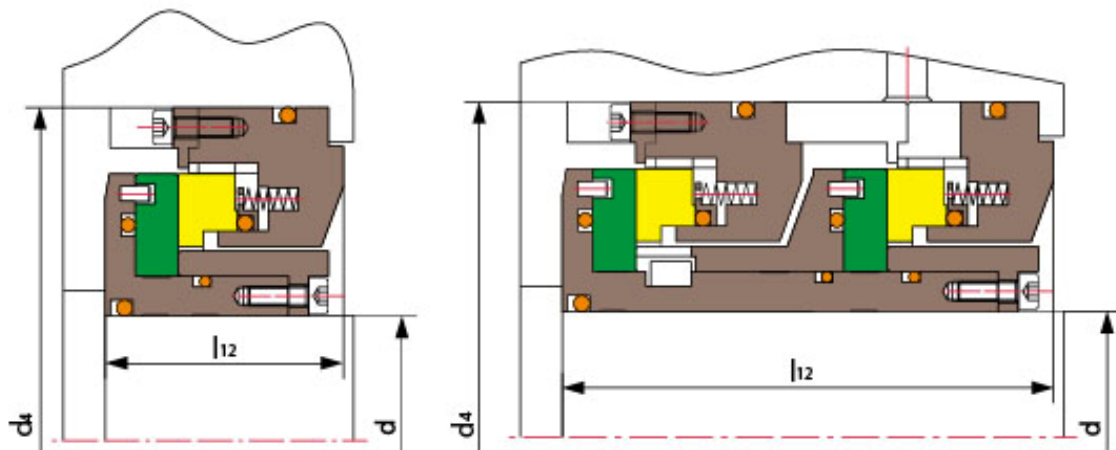
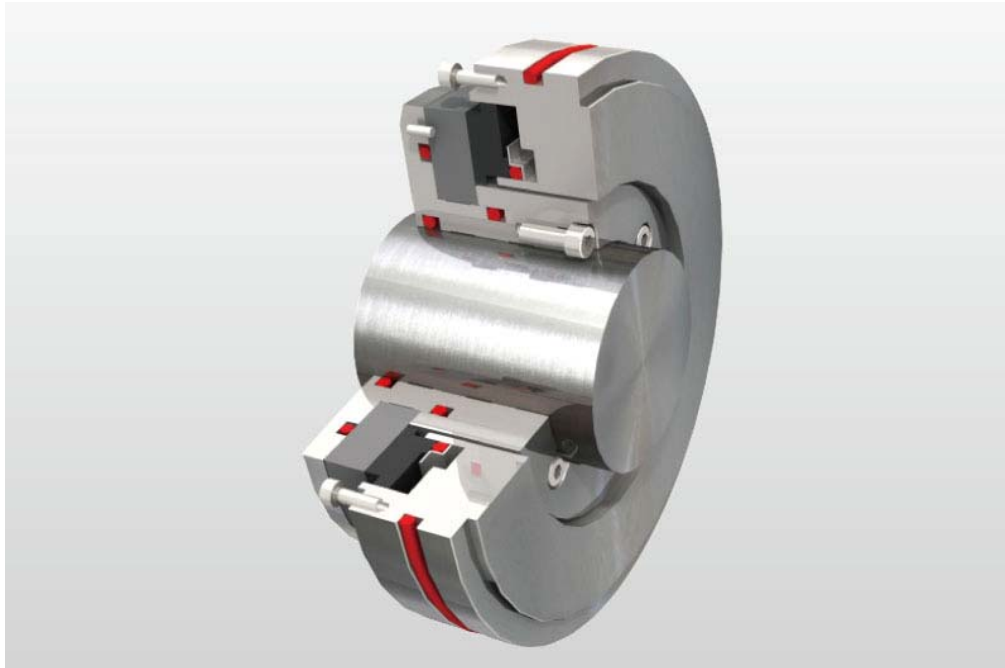

Rotary Ring (SiC/TC)

Stationary Ring (Carbon/SiC)

Secondary Seal (VITON/Encapsulated Ring/PTFE/EPDM/Kalrez)

Other Parts (SUS304/SUS316)

### Operating Limits

Pressure:  $\leq 12.4\text{MPa}$

---

**Shanghai Trisun Parts Manufacture Co.,Ltd.**

**Head office in Shanghai:**

Room 05-06, 16th Floor, Hongjia Building, No.388 Fushan Rd. (Near Xiangcheng Rd.), Pudong, Shanghai, China.

**Post Code:** 200122

**Tel:** +86-21-58355541,+86-21-58353145,+86-21-58353343

**Fax:** +86-21-58353141

**E-mail:** [trisunseal@yahoo.com.cn](mailto:trisunseal@yahoo.com.cn)



Speed: ≤180m/s

Temperature: -20℃~260℃

Seal Size (mm)	d Shaft Range	d <sub>4</sub>	l <sub>12</sub> Single Min	l <sub>12</sub> Tandem Min
56	25.4-29.0	104.8	46.4	99.2
62	29.0-34.9	111.9	46.8	99.2
68	35.0-41.3	119.5	47.2	99.6
75	41.3-46.8	126.2	47.2	99.6
81	46.8-53.2	133.7	47.6	100.0
87	53.2-59.5	140.9	48.4	100.4
94	59.5-65.1	148.0	48.8	100.8
100	65.1-71.4	155.2	48.8	100.8
106	71.4-77.0	162.3	49.2	101.2
113	77.0-82.9	169.4	50.0	101.6
119	77.0-88.9	177.0	50.0	101.6
125	88.9-94.8	183.7	50.8	102.8
132	94.9-101.2	191.3	51.6	104.4
128	101.2-107.1	198.4	52.0	104.8
144	107.2-113.1	205.6	52.8	106.3
151	113.1-119.0	212.7	53.6	108.0
156	119.1-123.4	217.9	54.8	109.5
162	123.4-129.8	225.4	55.1	110.7
168	129.8-135.7	232.6	55.5	111.5
175	135.7-141.7	239.7	56.3	112.3
181	141.7-147.6	246.8	57.2	114.3
187	147.7-153.6	254.0	57.9	115.9
194	153.6-159.9	261.1	58.7	117.5
200	159.9-165.9	268.7	59.5	119.0
206	165.9-171.8	277.8	59.9	119.5
213	171.9-177.4	285.3	60.7	121.0
219	177.4-183.3	292.1	61.5	122.2
225	183.4-189.7	299.6	62.3	123.8
232	189.7-195.7	306.8	63.1	125.4
238	195.7-201.6	313.9	63.5	126.2
244	201.6-207.5	321.1	64.3	127.8
251	207.6-213.5	328.2	65.1	129.4
257	213.5-219.9	335.4	65.5	130.2

---

**Shanghai Trisun Parts Manufacture Co.,Ltd.**

**Head office in Shanghai:**

Room 05-06, 16th Floor, Hongjia Building, No.388 Fushan Rd. (Near Xiangcheng Rd.), Pudong, Shanghai, China.

**Post Code:** 200122

**Tel:** +86-21-58355541,+86-21-58353145,+86-21-58353343

**Fax:** +86-21-58353141

**E-mail:** [trisunseal@yahoo.com.cn](mailto:trisunseal@yahoo.com.cn)



---

**Shanghai Trisun Parts Manufacture Co.,Ltd.**

**Head office in Shanghai:**

Room 05-06, 16th Floor, Hongjia Building, No.388 Fushan Rd. (Near Xiangcheng Rd.), Pudong, Shanghai, China.

**Post Code:** 200122

**Tel:** +86-21-58355541,+86-21-58353145,+86-21-58353343

**Fax:** +86-21-58353141

**E-mail:** [trisunseal@yahoo.com.cn](mailto:trisunseal@yahoo.com.cn)