

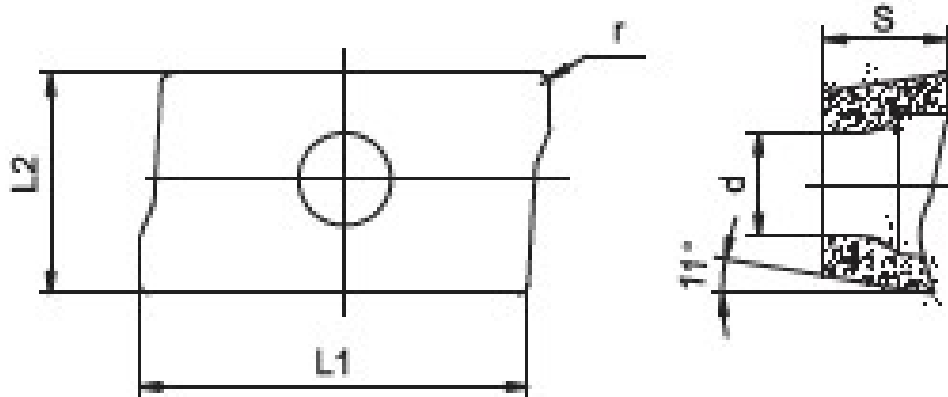

80° Diamond Indexable Insert

AP□□



Profile	Type	Dimension(mm)					Material grade	
		L ₁	L ₂	s	d	r	GG71	GG83
	APKT11T304	12.24	6.5	3.6	2.8	0.4	●	○
	APKT11T308					0.8	●	○
	APKT11T312					1.2	●	○
	APKT11T316					1.6	●	○
	APKT160408					17.877	9.33	5.76
	APMT1135	11.25	6.2	3.5	2.8	0.8	●	○
	APMT1104	17.25	9.25	4.76	4.4	0.8	●	○



Shanghai Trisun Parts Manufacture Co.,Ltd.

Head office in Shanghai:

Room 05-06, 16th Floor, Hongjia Building, No.388 Fushan Rd. (Near Xiangcheng Rd.), Pudong, Shanghai, China.

Post Code: 200122

Tel: +86-21-58355541,+86-21-58353145,+86-21-58353343

Fax: +86-21-58353141

E-mail: trisunseal@yahoo.com.cn



● Recommended type ○ Optional type(note: the followings are the same)

CN□□

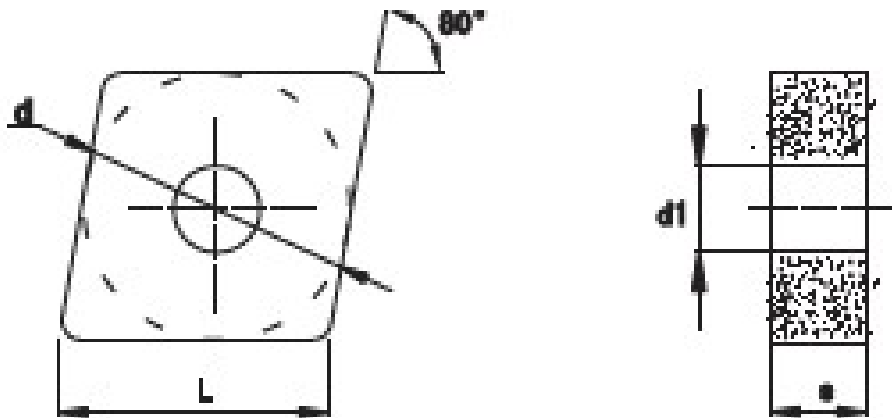

Profile	Type	Dimension(mm)					Material grade	
		L≈	d	s	d ₁	r	GG71	GG83
	CNMA120404	12.9	12.7	4.76	5.16	0.4	●	○
	CNMA120408					0.8	●	○
	CNMA120412					1.2	●	○
	CNMA120416					1.6	●	○
	CNMA160604					0.4	●	○

Shanghai Trisun Parts Manufacture Co.,Ltd.

Head office in Shanghai:

Room 05-06, 16th Floor, Hongjia Building, No.388 Fushan Rd. (Near Xiangcheng Rd.), Pudong, Shanghai, China.

Post Code: 200122

Tel: +86-21-58355541,+86-21-58353145,+86-21-58353343

Fax: +86-21-58353141

E-mail: trisunseal@yahoo.com.cn

	CNMA160608	19.3	19.05	6.35	7.94	0.8	●	○
	CNMA160612					1.2	●	○
	CNMA160616					1.6	●	○
	CNMA160620					2.0	●	○
	CNMA160630					3.0	●	○
	CNMA190612					1.2	●	○
	CNMA190616					1.6	●	○
	CNMG12040 4	12.9	12.7	4.76	5.16	0.4	●	○
	CNMG12040 8					0.8	●	○
	CNMG12041 2					1.2	●	○
	CNMG16060 4	16.1	15.875	6.35	6.35	0.4	●	○
	CNMG16060 8					0.8	●	○
	CNMG16061 2					1.2	●	○
	CNMG16061 6					1.6	●	○
	CNMG19060 8	19.3	19.05	6.35	7.94	0.8	●	○
	CNMG19061 2					1.2	●	○
	CNMG19061 6					1.6	●	○

CC□□

Shanghai Trisun Parts Manufacture Co.,Ltd.

Head office in Shanghai:

Room 05-06, 16th Floor, Hongjia Building, No.388 Fushan Rd. (Near Xiangcheng Rd.), Pudong, Shanghai, China.



Post Code: 200122

Tel: +86-21-58355541,+86-21-58353145,+86-21-58353343

Fax: +86-21-58353141

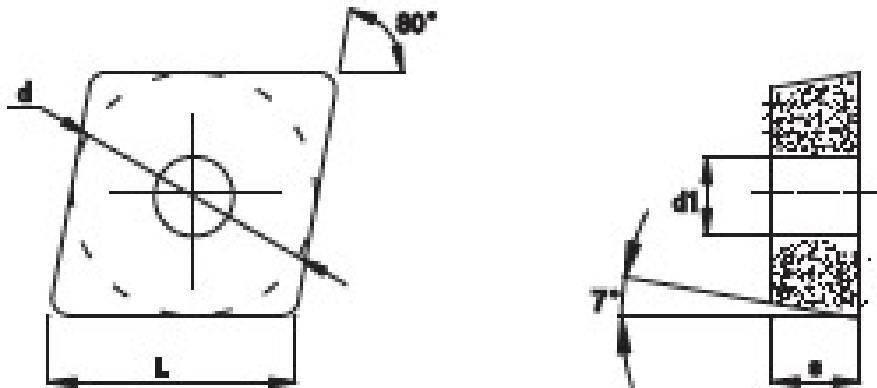
E-mail: trisunseal@yahoo.com.cn



Profile	Type	Dimension(mm)					Material grade	
		L≈	d	s	d ₁	r	GG83	GG71
	CCMT060204-GF	6.4	6.35	2.38	2.8	0.4	●	○
	CCMT060208-GF					0.8	●	○
	CCMT09T304-GF	9.7	9.525	3.97	4.4	0.4	●	○
	CCMT09T308-GF					0.8	●	○
	CCMT120404-GF	12.9	12.7	4.76	5.5	0.4	●	○
	CCMT120408-GF					0.8	●	○
	CCMW060204	6.4	6.35	2.38	2.8	0.4	●	○
	CCMW09T304	9.7	9.525	3.97	4.4	0.4	●	○
	CCMW09T308					0.8	●	○
	CCMW120404	12.9	12.7	4.76	5.5	0.4	●	○
	CCMW120408					0.8	●	○
	CCMT080308	8	8	3.18	3.4	0.8	●	○
	CCMT08T308	8	8	3.97	3.4	0.8	●	○
	CCMT09T308	9.7	9.525	3.97	4.4	0.8	●	○
	CCMT120408	12.9	12.7	4.76	5.5	0.8	●	○

DN□□

Shanghai Trisun Parts Manufacture Co.,Ltd.

Head office in Shanghai:

Room 05-06, 16th Floor, Hongjia Building, No.388 Fushan Rd. (Near Xiangcheng Rd.), Pudong, Shanghai, China.

Post Code: 200122

Tel: +86-21-58355541,+86-21-58353145,+86-21-58353343

Fax: +86-21-58353141

E-mail: trisunseal@yahoo.com.cn

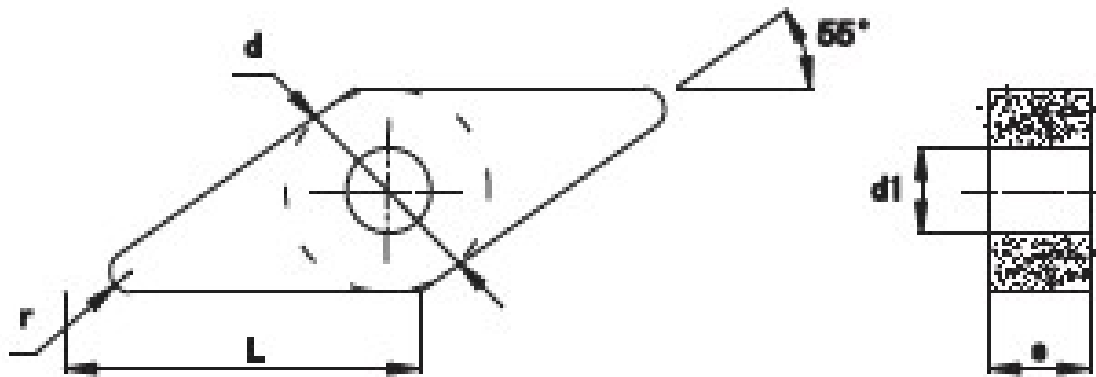

Profile	Type	Dimension(mm)					Material grade	
		L≈	d	s	d ₁	r	GG71	GG83
	DNNA110412	11.6	9.525	4.76	3.81	1.2	●	○
	DNNA110416					1.6	●	○
	DNNA110426					2.4	●	○
	DNNA150404	15.5	12.7	4.76	5.16	0.4	●	○
	DNNA150408					0.8	●	○
	DNNA150412					1.2	●	○
	DNNA150604	15.5	12.7	6.35	5.16	0.4	●	○
	DNNA150608					0.8	●	○
	DNNA150612					1.2	●	○
DNNA150616	1.6					●	○	
	DNNG110404-GM	11.6	9.525	4.76	3.81	0.4	●	○
	DNNG110408-GM					0.8	●	○
	DNNG110412-GM					1.2	●	○
	DNNG150404-GM	15.5	12.7	4.76	5.16	0.4	●	○
	DNNG150408-GM					0.8	●	○
	DNNG150412-GM					1.2	●	○
	DNNG150604-GM	15.5	12.7	6.35	5.16	0.4	●	○
	DNNG150608-GM					0.8	●	○
	DNNG150612-GM					1.2	●	○
	DNNG150616-GM					1.6	●	○

Shanghai Trisun Parts Manufacture Co.,Ltd.

Head office in Shanghai:

Room 05-06, 16th Floor, Hongjia Building, No.388 Fushan Rd. (Near Xiangcheng Rd.), Pudong, Shanghai, China.

Post Code: 200122

Tel: +86-21-58355541,+86-21-58353145,+86-21-58353343

Fax: +86-21-58353141

E-mail: trisunseal@yahoo.com.cn