



### Square Indexable Insert

SN□□

Profile	Type	Dimension(mm)					Material grade	
		L≈	d	s	d <sub>1</sub>	r	GG90	GG91
	SNMG090304-GM	9.525	9.525	3.18	3.81	0.4	●	○
	SNMG090308-GM					0.8	●	○
	SNMG090312-GM					1.2	●	○
	SNMG120404-GM	12.7	12.7	4.76	5.16	0.4	●	○
	SNMG120408-GM					0.8	●	○
	SNMG120412-GM					1.2	●	○
	SNMG150612-GM	15.875	15.875	6.35	6.35	1.2	●	○
	SNMG150616-GM					1.6	●	○
	SNMG190612-GM					1.2	●	○
	SNMG190616-GM	19.05	19.05	6.35	7.94	1.6	●	○
	SNMG190624-GM					2.4	●	○

Profile	Type	Dimension(mm)					Material grade		
		L≈	d	s	d <sub>1</sub>	r	GG90	GG91	GG71
	SNMG090304-GR1	9.525	9.525	3.18	3.81	0.4	●	○	
	SNMG090308-GR1					0.8	●	○	
	SNMG090312-GR1					1.2	●	○	
	SNMG120404-GR1	12.7	12.7	4.76	5.16	0.4	●	○	
	SNMG120408-GR1					0.8	●	○	
	SNMG120412-GR1					1.2	●	○	
	SNMG150612-GR1	15.875	15.875	6.35	6.35	1.2	●	○	
	SNMG150616-GR1					1.6	●	○	
	SNMG190612-GR1					1.2	●	○	
	SNMG190616-GR1	19.05	19.05	6.35	7.94	1.6	●	○	
	SNMG190624-GR1					2.4	●	○	
SNMG190612-GR2	1.2					●	○		
SNMG190616-GR2	19.05	19.05	6.35	7.94	1.6	●	○		
SNMG190624-GR2					2.4	●	○		
SNMG250724-GR2					2.4	●	○		
SNMG250924-GR2	25.4	25.4	9.52	9.12	2.4	●	○		
SNMG090304-GR2	9.525	9.525	3.18	3.81	0.4	●	○		

**Shanghai Trisun Parts Manufacture Co.,Ltd.**

**Head office in Shanghai:**

Room 05-06, 16th Floor, Hongjia Building, No.388 Fushan Rd. (Near Xiangcheng Rd.), Pudong, Shanghai, China.

**Post Code:** 200122

**Tel:** +86-21-58355541,+86-21-58353145,+86-21-58353343

**Fax:** +86-21-58353141

**E-mail:** [trisunseal@yahoo.com.cn](mailto:trisunseal@yahoo.com.cn)



SNMG090308-GR2					0.8	●	○
SNMG120408-GR2					0.8	●	○
SNMG120412-GR2					1.2	●	○
SNMG120416-GR2	12.7	12.7	4.76	5.16	1.6	●	○
SNMG190608-GR2					0.8	●	○
SNMG190612-GR2					1.2	●	○
SNMG190616-GR2	19.05	19.05	6.35	7.94	1.6	●	○
SNMG250724-GR2					2.4	●	○
SNMG250924-GR2	25.4	25.4	7.94	9.12	2.4	●	○

SNMM150616-GR	15.875	15.875	6.35	6.35	1.6	●	○	
SNMM190616-GR	19.05	19.05	6.35	6.35	1.6	●	○	
SNMM250916-GR					1.6	●	○	
SNMM250924-GR	25.4	25.4	9.52	9.12	2.4	●	○	
SNMM090304					0.4	●	○	
SNMM090308					0.8	●	○	
SNMM090312	9.525	9.525	3.18	3.81	1.2	●	○	
SNMM120408					0.8	●	○	
SNMM120412	12.7	12.7	4.76	5.16	1.2	●	○	
SNMM190608					0.8	●	○	
SNMM190612					1.2	●	○	
SNMM190624	19.05	19.05	6.35	6.35	2.4	●	○	
SNMM250724	25.4	25.4	7.94	9.12	2.4	●	○	
SNMM250724-F			7.94		2.4	●	○	
SNMM250924-F	25.4	25.4	9.52	9.12	2.4	●	○	
SNMA090304					0.4		○	●
SNMA090308	9.525	9.525	3.18	3.81	0.8		○	●
SNMA120408					0.8		○	●
SNMA120412					1.2		○	●
SNMA120416	12.7	12.7	4.76	5.16	1.6		○	●
SNMA150616	15.875	15.875	6.35	6.35	1.6		○	●
SNMA190608					0.8		○	●
SNMA190612					1.2		○	●
SNMA190616	19.05	19.05	6.35	7.94	1.6		○	●

SN□□

**Shanghai Trisun Parts Manufacture Co.,Ltd.**

**Head office in Shanghai:**

Room 05-06, 16th Floor, Hongjia Building, No.388 Fushan Rd. (Near Xiangcheng Rd.), Pudong, Shanghai, China.

**Post Code:** 200122

**Tel:** +86-21-58355541,+86-21-58353145,+86-21-58353343

**Fax:** +86-21-58353141

**E-mail:** [trisunseal@yahoo.com.cn](mailto:trisunseal@yahoo.com.cn)

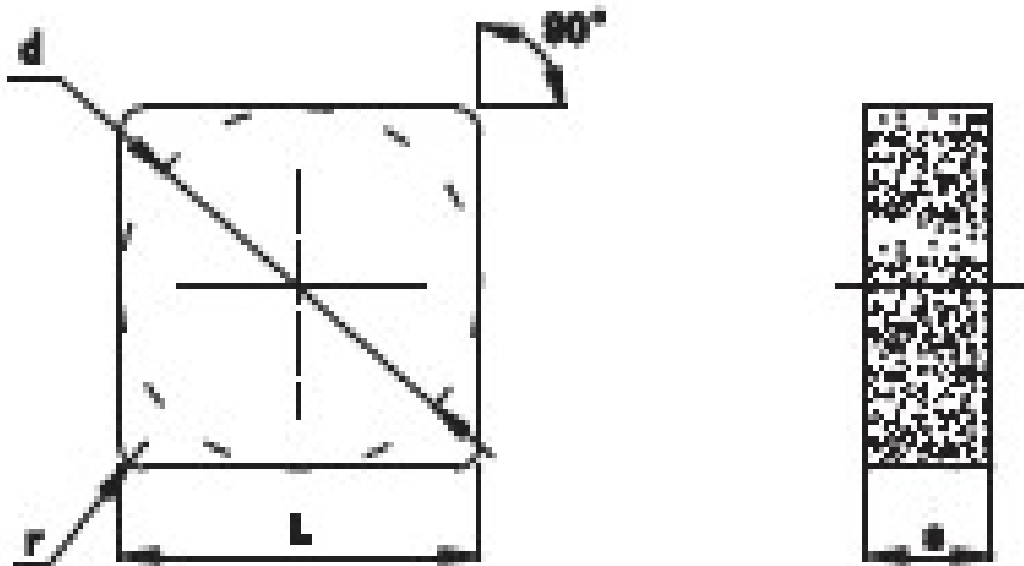

Profile	Type	Dimension(mm)					Material grade	
		L≈	d	s	d <sub>1</sub>	r	GG53	GG83
	SNGN090308	9.525	9.525	3.18		0.8	○	●
	SNGN120408	12.7	12.7	4.76		0.8	○	●
	SNGN150408	15.875	15.875	4.76		0.8	○	●
	SNGN190412	19.05	19.05	4.76		1.2	○	●
	SNUM090304					0.4	○	●
	SNUM090308	9.525	9.525	3.18		0.8	○	●
	SNUM120408					0.8	○	●
	SNUM120412	12.7	12.7	4.76		1.2	○	●
	SNUM150408					0.8	○	●
	SNUM150412	15.875	15.875	4.76		1.2	○	●
	SNUM190412					1.2	○	●
	SNUM190424	19.05	19.05	4.76		2.4	○	●
	SNUM250724	25.4	25.4	7.94		2.4	○	●
	SNUM250924	25.4	25.4	9.52		2.4	○	●

SC□□

**Shanghai Trisun Parts Manufacture Co.,Ltd.**

**Head office in Shanghai:**

Room 05-06, 16th Floor, Hongjia Building, No.388 Fushan Rd. (Near Xiangcheng Rd.), Pudong, Shanghai, China.

**Post Code:** 200122

**Tel:** +86-21-58355541,+86-21-58353145,+86-21-58353343

**Fax:** +86-21-58353141

**E-mail:** [trisunseal@yahoo.com.cn](mailto:trisunseal@yahoo.com.cn)

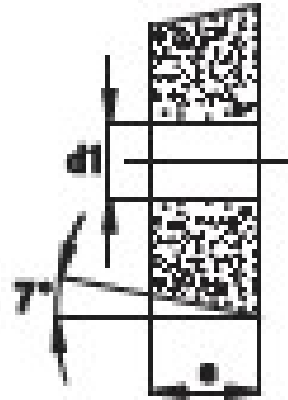
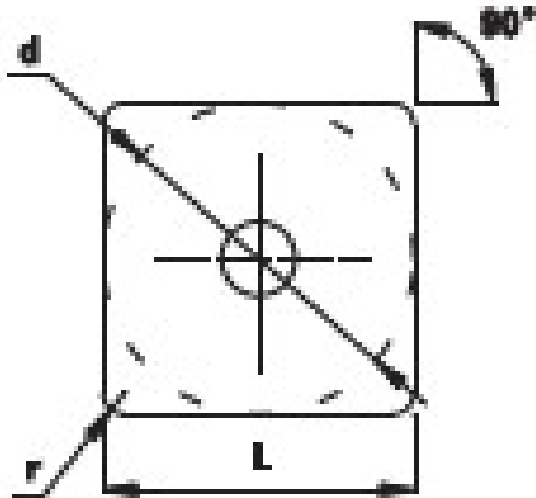

---

**Shanghai Trisun Parts Manufacture Co.,Ltd.**

**Head office in Shanghai:**

Room 05-06, 16th Floor, Hongjia Building, No.388 Fushan Rd. (Near Xiangcheng Rd.), Pudong, Shanghai, China.

**Post Code:** 200122

**Tel:** +86-21-58355541,+86-21-58353145,+86-21-58353343

**Fax:** +86-21-58353141

**E-mail:** [trisunseal@yahoo.com.cn](mailto:trisunseal@yahoo.com.cn)