

## TSMB-J13 28mm-100mm Metal Bellows Seal

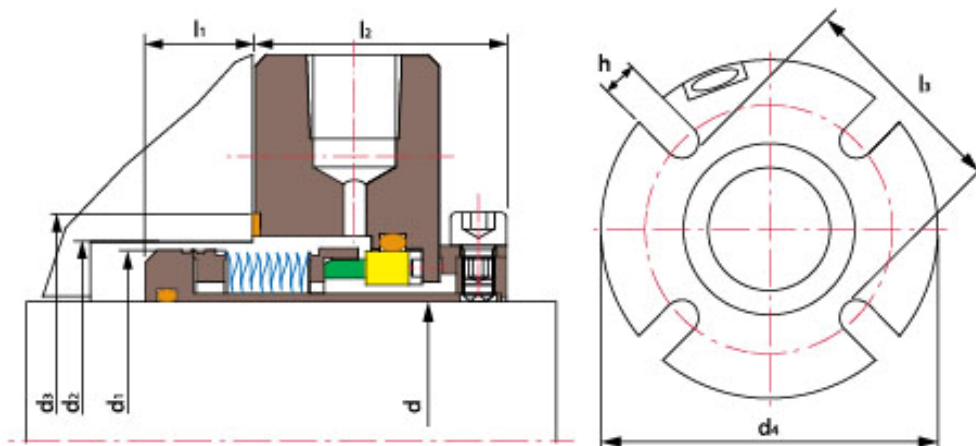

### Operating Limits

Pressure:  $\leq 2\text{MPa}$

Speed:  $\leq 25\text{m/s}$

Temperature:  $-30^{\circ}\text{C} \sim +200^{\circ}\text{C}$

Rotary Ring (SiC/Carbon/TC)

---

**Shanghai Trisun Parts Manufacture Co.,Ltd.**

**Head office in Shanghai:**

Room 05-06, 16th Floor, Hongjia Building, No.388 Fushan Rd. (Near Xiangcheng Rd.), Pudong, Shanghai, China.

**Post Code:** 200122

**Tel:** +86-21-58355541,+86-21-58353145,+86-21-58353343

**Fax:** +86-21-58353141

**E-mail:** [trisunseal@yahoo.com.cn](mailto:trisunseal@yahoo.com.cn)



Stationary Ring (SiC/TC)

Secondary Seal (VITON/Encapsulated Ring/PTFE)

Metal Bellows (SUS316L/AM350/Inconel718 /Titanium/Hastelloy-C/Alloy-20)

Other Parts (SUS304/SUS316/Titanium/Hastelloy-C)

d (mm)	d <sub>1</sub>	d <sub>2</sub>	d <sub>3</sub>	l <sub>1</sub>	l <sub>2</sub>	l <sub>3</sub>	h	d <sub>4</sub>
28	42.8	49.2	60.3	17.4	42.9	61.9	14.3	111.1
33	49.2	52.4	60.3	17.4	39.7	61.9	14.3	106.0
35	49.2	52.4	60.3	17.4	39.7	61.9	14.3	106.0
38	55.5	58.7	69.8	19.0	42.9	71.5	14.3	130.2
40	58.7	61.9	71.4	19.1	42.8	73.0	14.3	133.4
43	61.9	65.7	79.4	19.1	42.9	81.0	14.3	133.4
45	61.9	65.1	79.4	19.1	42.9	81.0	14.3	133.4
48	65.1	68.3	82.6	19.0	44.5	84.2	17.4	139.7
50	68.2	71.4	83.6	19.0	44.5	84.2	17.4	138.0
53	71.4	74.6	88.9	22.2	42.9	90.5	17.4	138.0
55	71.4	74.6	88.9	22.2	42.9	90.5	17.4	138.0
60	80.9	84.1	96.8	25.4	41.3	98.4	17.4	158.8
65	87.3	90.5	109.5	30.2	41.2	111.1	17.4	177.8
70	92.1	95.2	114.3	27.0	41.2	115.9	17.5	190.0
75	98.4	101.6	122.2	28.5	42.1	123.8	20.6	196.9
80	104.8	108.0	125.4	28.5	42.1	127.0	19.1	190.0
85	108.0	111.1	125.4	31.7	42.1	127.0	19.1	203.2
100	128.6	131.8	154.0	34.9	42.1	155.6	22.2	228.6

---

**Shanghai Trisun Parts Manufacture Co.,Ltd.**

**Head office in Shanghai:**

Room 05-06, 16th Floor, Hongjia Building, No.388 Fushan Rd. (Near Xiangcheng Rd.), Pudong, Shanghai, China.

**Post Code:** 200122

**Tel:** +86-21-58355541,+86-21-58353145,+86-21-58353343

**Fax:** +86-21-58353141

**E-mail:** [trisunseal@yahoo.com.cn](mailto:trisunseal@yahoo.com.cn)