

## TSMB-B06 25mm-80mm Metal Bellows Seal

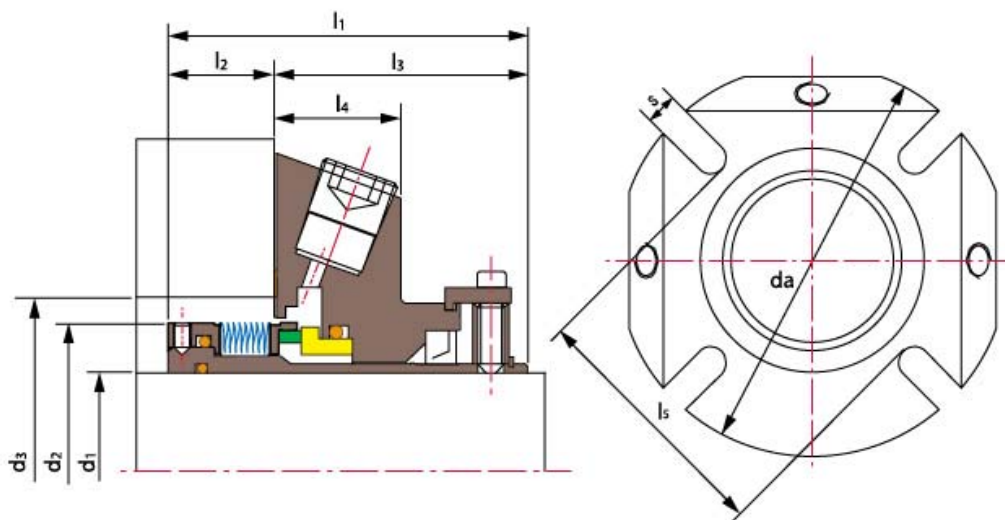

### Operating Limits

Pressure:  $\leq 2\text{MPa}$

Speed:  $\leq 25\text{m/s}$

Temperature:  $-40^{\circ}\text{C} \sim +220^{\circ}\text{C}$

Rotary Ring (SiC/Carbon/TC)

Stationary Ring (SiC/TC)

---

**Shanghai Trisun Parts Manufacture Co.,Ltd.**

**Head office in Shanghai:**

Room 05-06, 16th Floor, Hongjia Building, No.388 Fushan Rd. (Near Xiangcheng Rd.), Pudong, Shanghai, China.

**Post Code:** 200122

**Tel:** +86-21-58355541,+86-21-58353145,+86-21-58353343

**Fax:** +86-21-58353141

**E-mail:** [trisunseal@yahoo.com.cn](mailto:trisunseal@yahoo.com.cn)



Secondary Seal (VITON/Encapsulated Ring/PTFE)

Metal Bellows (SUS316L/AM350/Inconel718/Titanium/Hastelloy-C/Alloy-20)

Other Parts (SUS304/SUS316/Titanium/Hastelloy-C)

d <sub>3</sub>		l <sub>1</sub>	l <sub>2</sub>	l <sub>3</sub>	l <sub>4</sub>	d <sub>a</sub>	1	s
min	max							
47.0	51.0	79.5	26.1	53.4	25.4	105.0	62.0	13.2
52.0	56.0	78.4	25.0	53.4	25.4	105.0	67.0	13.2
54.5	57.0	78.4	25.0	53.4	25.4	108.0	70.0	13.2
54.5	57.0	78.4	25.0	53.4	25.4	108.0	70.0	13.2
58.0	61.5	78.4	25.0	53.4	25.4	113.0	72.0	13.2
60.0	66.0	78.4	25.0	53.4	25.4	123.0	75.0	14.0
62.0	68.0	78.2	24.8	53.4	25.4	123.0	77.0	14.2
64.5	70.5	78.4	25.0	53.4	25.4	133.0	80.0	14.2
68.5	73.0	78.4	25.0	53.4	25.4	138.0	82.0	14.2
71.0	75.0	78.7	25.3	53.4	25.4	138.0	85.0	14.2
73.0	78.0	79.1	25.7	53.4	25.4	148.0	87.0	14.2
75.0	87.0	77.8	24.4	53.4	25.4	148.0	97.0	18.0
77.0	83.0	78.9	25.5	53.4	25.4	148.0	92.0	18.0
87.0	91.0	80.1	26.7	53.4	25.4	157.0	102.0	18.0
90.0	98.5	80.0	26.6	53.4	25.4	163.0	109.3	18.0
98.0	108.0	81.5	28.1	53.4	25.4	178.0	118.3	18.0
101.6	118.0	94.4	30.5	63.9	28.0	190.0	129.0	18.0
108.0	124.0	94.4	30.4	64.0	28.0	195.0	135.0	18.0

---

**Shanghai Trisun Parts Manufacture Co.,Ltd.**

**Head office in Shanghai:**

Room 05-06, 16th Floor, Hongjia Building, No.388 Fushan Rd. (Near Xiangcheng Rd.), Pudong, Shanghai, China.

**Post Code:** 200122

**Tel:** +86-21-58355541,+86-21-58353145,+86-21-58353343

**Fax:** +86-21-58353141

**E-mail:** [trisunseal@yahoo.com.cn](mailto:trisunseal@yahoo.com.cn)