

TSMB-A04 24mm-100mm Metal Bellows Seal

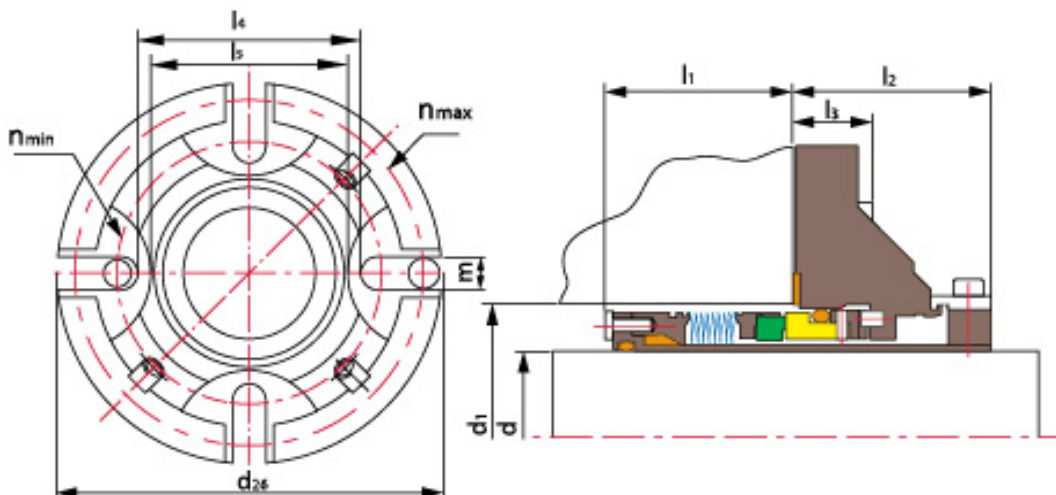

Operating Limits

Pressure: $\leq 2\text{MPa}$

Speed: $\leq 20\text{m/s}$

Temperature: $-30^{\circ}\text{C} \sim +204^{\circ}\text{C}$

Rotary Ring (SiC/Carbon/TC)

Stationary Ring (SiC/TC)

Secondary Seal (VITON/Encapsulated Ring/PTFE/Flexible Carbon)

Shanghai Trisun Parts Manufacture Co.,Ltd.

Head office in Shanghai:

Room 05-06, 16th Floor, Hongjia Building, No.388 Fushan Rd. (Near Xiangcheng Rd.), Pudong, Shanghai, China.

Post Code: 200122

Tel: +86-21-58355541,+86-21-58353145,+86-21-58353343

Fax: +86-21-58353141

E-mail: trisunseal@yahoo.com.cn



Metal Bellows (SUS316L/AM350/Inconel718/Titanium/Hastelloy-C/Alloy-20)

Other Parts (SUS304/SUS316/Tianium/Hastelloy-C)

d (mm)	d ₂₆	l ₄	l ₅	l ₃	d ₁		n		m	l ₁	l ₂
					min	max	min	max	max		
24	104.8	54.0	49.2	13.2	41.0	49.0	67.0	90.5	12	38.9	40.5
25	104.8	54.0	49.2	13.2	41.0	49.0	67.0	90.5	12	38.9	40.5
28	108.0	57.2	52.4	13.2	44.0	52.3	70.3	93.6	12	38.9	40.5
30	111.0	60.4	55.6	13.2	46.0	55.5	73.5	96.8	12	38.9	40.5
32	111.0	60.4	55.6	13.2	48.0	55.5	73.5	96.8	12	38.9	40.5
33	111.0	60.4	55.6	13.2	49.0	55.5	73.5	96.8	12	38.9	40.5
35	111.0	63.5	58.8	13.2	51.0	57.5	76.6	96.8	12	38.9	40.5
38	127.0	71.5	65.0	16.4	57.2	60.4	85.7	114.3	12	42.9	44.5
40	127.0	71.5	65.0	16.4	58.0	60.4	85.7	114.3	12	42.9	44.5
43	139.7	81.0	71.4	16.4	61.0	69.9	95.3	127.0	12	42.9	44.5
45	139.7	81.0	71.4	16.4	63.5	69.9	95.3	127.0	12	42.9	44.5
48	139.7	81.0	71.4	16.4	66.7	73.0	95.3	127.0	12	42.9	44.5
50	152.4	90.5	77.8	16.4	68.0	76.2	104.8	139.7	12	44.5	44.5
3	152.4	90.5	77.8	16.4	71.0	76.2	104.8	139.7	12	44.5	44.5
55	165.1	96.8	84.1	16.4	74.0	82.5	114.3	149.2	16	44.5	44.5
58	165.1	96.8	84.1	16.4	76.2	82.6	114.3	149.2	16	44.5	44.5
60	165.1	96.8	84.1	16.4	79.4	85.7	114.3	149.2	16	44.5	44.5

Shanghai Trisun Parts Manufacture Co.,Ltd.

Head office in Shanghai:

Room 05-06, 16th Floor, Hongjia Building, No.388 Fushan Rd. (Near Xiangcheng Rd.), Pudong, Shanghai, China.

Post Code: 200122

Tel: +86-21-58355541,+86-21-58353145,+86-21-58353343

Fax: +86-21-58353141

E-mail: trisunseal@yahoo.com.cn

63	177. 8	109. 5	96.8	19. 6	85.8	92.1	127. 0	160. 3	16	51. 6	47. 7
65	177. 8	109. 5	96.8	19. 6	88.9	95.3	127. 0	160. 3	16	51. 6	47. 7
68	177. 8	109. 5	96.8	19. 6	92.1	98.4	127. 0	160. 3	16	51. 6	47. 7
70	177. 8	109. 5	96.8	19. 6	92.1	98.4	127. 0	160. 3	16	51. 6	47. 7
75	190. 5	125. 4	108. 0	19. 6	98.5	108. 0	142. 9	173. 0	16	54. 6	47. 7
80	190. 5	125. 4	108. 0	19. 6	101. 6	111. 1	142. 9	173. 0	16	54. 6	47. 7
85	203. 2	135. 0	117. 5	19. 6	108. 0	117. 5	155. 6	182. 5	20	54. 6	47. 7
90	215. 9	150. 8	127. 0	19. 6	114. 3	127. 0	171. 5	195. 2	20	54. 6	47. 7
95	215. 9	150. 8	127. 0	19. 6	117. 5	130. 2	171. 5	195. 2	20	54. 6	47. 7
100	228. 6	168. 3	136. 5	19. 6	123. 9	139. 7	188. 9	207. 9	20	54. 6	47. 7

Shanghai Trisun Parts Manufacture Co.,Ltd.

Head office in Shanghai:

Room 05-06, 16th Floor, Hongjia Building, No.388 Fushan Rd. (Near Xiangcheng Rd.), Pudong, Shanghai, China.

Post Code: 200122

Tel: +86-21-58355541,+86-21-58353145,+86-21-58353343

Fax: +86-21-58353141

E-mail: trisunseal@yahoo.com.cn