

## TSMB-A04 1.000-4.000(inches)Metal Bellows Seal

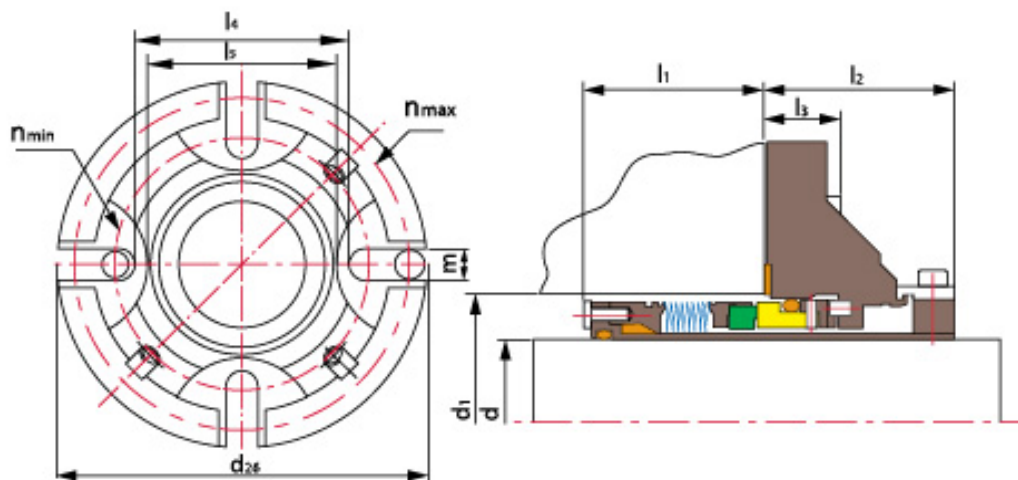

### Operating Limits

Pressure:  $\leq 2\text{MPa}$

Speed:  $\leq 20\text{m/s}$

Temperature:  $-30^{\circ}\text{C} \sim +204^{\circ}\text{C}$

Rotary Ring (SiC/Carbon/TC)

Stationary Ring (SiC/TC)

---

**Shanghai Trisun Parts Manufacture Co.,Ltd.**

**Head office in Shanghai:**

Room 05-06, 16th Floor, Hongjia Building, No.388 Fushan Rd. (Near Xiangcheng Rd.), Pudong, Shanghai, China.

**Post Code:** 200122

**Tel:** +86-21-58355541,+86-21-58353145,+86-21-58353343

**Fax:** +86-21-58353141

**E-mail:** [trisunseal@yahoo.com.cn](mailto:trisunseal@yahoo.com.cn)



Secondary Seal (VITON/Encapsulated Ring/PTFE/Flexible Carbon)  
 Metal Bellows (SUS316L/AM350/Inconel718/Titanium/Hastelloy-C/Alloy-20)  
 Other Parts (SUS304/SUS316/Titanium/Hastelloy-C)

d (inches)	d <sub>26</sub>	l <sub>4</sub>	l <sub>5</sub>	l <sub>3</sub>	d <sub>1</sub>		n		m	l <sub>1</sub>	l <sub>2</sub>
					min	max	min	max	max		
1.000	4.1 25	2.1 25	1.9 37	0.5 19	1.6 25	1.9 37	2.6 87	3.5 62	1/ 2	1.5 31	1.5 90
1.125	4.2 50	2.2 50	2.0 63	0.5 19	1.7 50	2.0 62	2.8 12	3.6 87	1/ 2	1.5 31	1.5 90
1.250	4.3 75	2.3 75	2.1 87	1.5 19	1.8 75	2.1 87	2.9 37	3.8 12	1/ 2	1.5 31	1.5 90
1.375	4.3 75	2.5 00	2.3 12	0.5 19	2.0 00	2.2 50	3.0 62	3.8 12	1/ 2	1.5 31	1.5 90
1.500	5.0 00	2.8 12	2.5 62	0.6 44	2.2 50	2.3 75	3.3 75	4.4 37	1/ 2	1.6 87	1.7 52
1.625	5.0 00	2.8 12	2.5 62	0.6 44	2.3 75	2.5 00	3.3 75	4.4 37	1/ 2	1.6 87	1.7 52
1.750	5.5 00	3.1 87	2.8 12	0.6 44	2.5 00	2.7 50	3.7 50	4.9 37	1/ 2	1.6 87	1.7 52
1.875	5.5 00	3.1 87	2.8 12	0.6 44	2.6 25	2.8 75	3.7 50	4.9 37	1/ 2	1.6 87	1.7 52
2.000	6.0 00	3.5 62	3.0 63	0.6 44	2.7 50	3.0 00	4.1 25	5.4 37	1/ 2	1.7 50	1.7 52
2.000- AC	5.2 50	3.4 50	3.0 35	0.6 44	2.7 50	3.0 00	4.0 00	4.7 50	1/ 2	1.7 50	1.7 52
2.125	6.0 00	3.5 62	3.0 63	0.6 44	2.8 75	3.1 25	4.1 25	5.4 37	1/ 2	1.7 50	1.7 52
2.250	6.5 00	3.8 12	3.3 12	0.6 44	3.0 00	3.2 50	4.5 00	5.8 12	5/ 8	1.7 50	1.7 52
2.375	6.5 00	3.8 12	3.3 12	0.6 44	3.1 25	3.3 75	4.5 00	5.8 12	5/ 8	1.7 50	1.7 52
2.500	7.0 00	4.3 12	3.8 12	0.7 69	3.3 75	3.6 25	5.0 00	6.3 12	5/ 8	2.0 31	1.8 77
2.625	7.0 00	4.3 12	3.8 12	0.7 69	3.5 00	3.7 50	5.0 00	6.3 12	5/ 8	2.0 31	1.8 77
2.750	7.0 00	4.3 12	3.8 12	0.7 69	3.6 25	3.8 75	5.0 00	6.3 12	5/ 8	2.0 31	1.8 77
2.875	7.5	4.9	4.2	0.7	3.7	4.1	5.6	6.8	5/	2.0	1.8

**Shanghai Trisun Parts Manufacture Co.,Ltd.**

**Head office in Shanghai:**

Room 05-06, 16th Floor, Hongjia Building, No.388 Fushan Rd. (Near Xiangcheng Rd.), Pudong, Shanghai, China.

**Post Code:** 200122

**Tel:** +86-21-58355541,+86-21-58353145,+86-21-58353343

**Fax:** +86-21-58353141

**E-mail:** [trisunseal@yahoo.com.cn](mailto:trisunseal@yahoo.com.cn)

	00	37	50	69	50	25	25	12	8	31	77
3.000	7.5 00	4.9 37	4.2 50	0.7 69	3.8 75	4.2 50	5.6 25	6.8 12	5/ 8	2.1 50	1.8 77
3.125	7.5 00	4.9 37	4.2 50	0.7 69	4.0 00	4.3 75	5.6 25	6.8 12	5/ 8	2.1 50	1.8 77
3.250	8.0 00	5.3 12	4.6 25	0.7 69	4.1 25	4.5 00	6.1 25	7.1 87	3/ 4	2.1 50	1.8 77
3.375	8.0 00	5.3 12	4.6 25	0.7 69	4.2 50	4.6 25	6.1 25	7.1 87	3/ 4	2.1 50	1.8 77
3.500	8.0 00	5.3 12	4.6 25	0.7 69	4.3 75	4.7 50	6.1 25	7.1 87	3/ 4	2.1 50	1.8 77
3.625	8.5 00	5.9 37	5.0 00	0.7 69	4.5 00	5.0 00	6.7 50	7.6 87	3/ 4	2.1 50	1.8 77
3.750	8.5 00	7.9 37	5.0 00	0.7 69	4.6 25	5.1 25	6.7 50	7.6 87	3/ 4	2.1 50	1.8 77
3.875	9.0 00	6.6 25	5.3 75	0.7 69	4.8 75	5.5 00	7.4 37	8.1 87	3/ 4	2.1 50	1.8 77
4.000	9.0 00	6.6 25	5.3 75	0.7 69	4.8 75	5.5 00	7.4 37	8.1 87	3/ 4	2.1 50	1.8 77

---

**Shanghai Trisun Parts Manufacture Co.,Ltd.**

**Head office in Shanghai:**

Room 05-06, 16th Floor, Hongjia Building, No.388 Fushan Rd. (Near Xiangcheng Rd.), Pudong, Shanghai, China.

**Post Code:** 200122

**Tel:** +86-21-58355541,+86-21-58353145,+86-21-58353343

**Fax:** +86-21-58353141

**E-mail:** [trisunseal@yahoo.com.cn](mailto:trisunseal@yahoo.com.cn)