

**TSMB-J07 1.000-3.000(inches) Metal Bellows Seal**

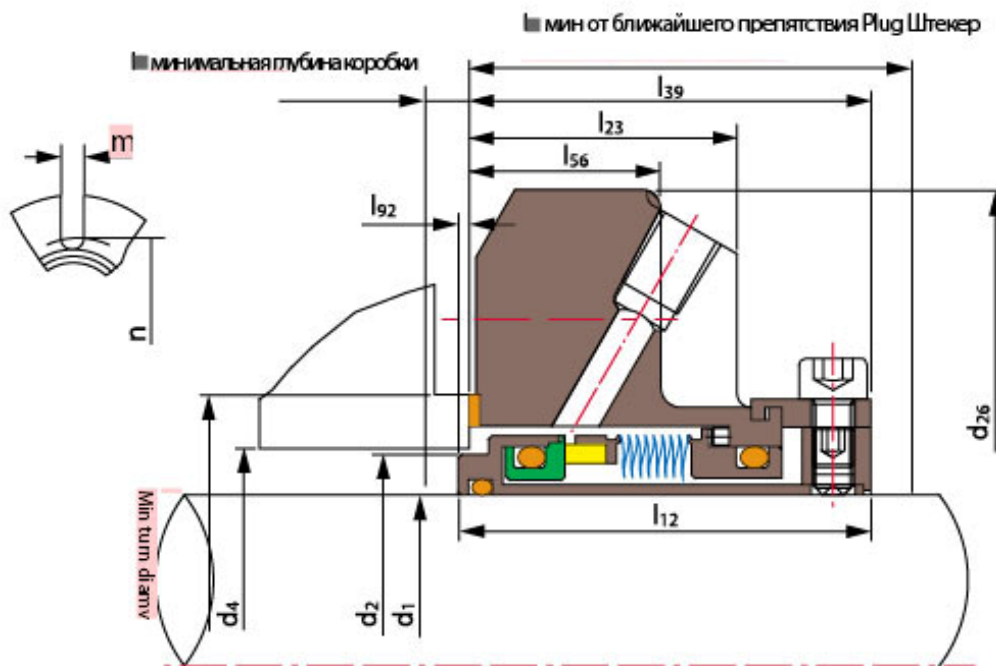

- Rotary Ring (SiC/TC)
- Stationary Ring (SiC/Carbon/TC)
- Secondary Seal (VITON/Fncapsulated Ring/PTFE)

**Shanghai Trisun Parts Manufacture Co.,Ltd.**

**Head office in Shanghai:**

Room 05-06, 16th Floor, Hongjia Building, No.388 Fushan Rd. (Near Xiangcheng Rd.), Pudong, Shanghai, China.

**Post Code:** 200122

**Tel:** +86-21-58355541,+86-21-58353145,+86-21-58353343

**Fax:** +86-21-58353141

**E-mail:** [trisunseal@yahoo.com.cn](mailto:trisunseal@yahoo.com.cn)



Metal Bellows (SUS316L/AM350/Inconel718/Titanium/Hastelloy-C/Alloy-20)

Other Parts (SUS304/SUS316/Titanium/Hastelloy-C)

**Operating Limits:**

Pressure: ≤2.1MPa

Speed: ≤25m/s

Temperature: -30℃~+205℃

d <sub>1</sub> (inches)	d <sub>2</sub>	d <sub>4</sub>		d <sub>26</sub>	l <sub>12</sub>	l <sub>23</sub>	l <sub>39</sub>	l <sub>56</sub>	l <sub>90</sub>	l <sub>91</sub>	l <sub>92</sub>	m	n
		min	max										
1.000	1.375	1.400	1.800	4.000	1.900	1.300	1.900	0.531	2.000	0.160	0.035	0.525	2.905
1.125	1.500	\	2.015	4.125	2.000	1.400	2.000	0.531	2.100	0.125	\	0.525	2.933
1.250	1.625	\	2.200	4.250	2.000	1.400	2.000	0.531	2.100	0.125	\	0.525	3.213
1.375	1.750	\	2.400	4.375	2.000	1.400	2.000	0.531	2.100	0.125	\	0.525	3.338
1.500	1.875	2.000	2.600	4.875	2.100	1.400	2.100	0.531	2.100	0.100	0.031	0.525	3.599
1.625	2.000	2.100	2.800	5.000	2.100	1.400	2.100	0.531	2.100	0.100	0.031	0.525	3.766
1.750	2.125	2.200	2.900	5.200	2.100	1.400	2.100	0.531	2.100	0.100	0.031	0.525	3.875
1.875	2.250	2.300	2.900	5.200	2.100	1.400	2.100	0.531	2.100	0.100	0.031	0.525	3.875
2.000	2.375	2.500	3.000	5.500	2.300	1.600	2.300	1.063	2.300	0.100	0.062	0.525	4.000
2.125	2.500	2.600	3.300	5.800	2.300	1.600	2.300	0.531	2.300	0.100	0.062	0.600	4.469
2.250	2.625	2.700	3.400	6.500	2.300	1.600	2.300	0.531	2.300	0.100	0.062	0.600	4.566
2.375	2.750	2.800	3.600	6.500	2.400	1.700	2.400	0.625	2.500	0.100	0.018	0.600	4.719
2.500	3.000	\	3.800	6.700	2.400	1.700	2.500	0.625	2.600	0.100	\	0.600	5.000
2.625	3.300	\	4.000	6.700	2.500	1.600	2.500	0.625	2.500	0.100	\	0.600	5.170
2.750	3.300	\	4.000	6.700	2.500	1.600	2.500	0.625	2.500	0.100	\	0.600	5.170

**Shanghai Trisun Parts Manufacture Co.,Ltd.**

**Head office in Shanghai:**

Room 05-06, 16th Floor, Hongjia Building, No.388 Fushan Rd. (Near Xiangcheng Rd.), Pudong, Shanghai, China.

**Post Code:** 200122

**Tel:** +86-21-58355541,+86-21-58353145,+86-21-58353343

**Fax:** +86-21-58353141

**E-mail:** [trisunseal@yahoo.com.cn](mailto:trisunseal@yahoo.com.cn)



	12		62	50	00	25	00	25	62	25		87	70
2.875	3.3	\	4.1	7.0	2.5	1.7	2.5	0.6	2.5	0.1	\	0.6	5.3
	75		86	00	00	25	00	25	62	25		87	12
3.000	3.6	\	4.4	7.7	2.5	1.7	2.5	0.6	2.6	0.1	\	0.8	5.7
	25		69	50	00	87	62	85	25	25		12	20

---

**Shanghai Trisun Parts Manufacture Co.,Ltd.**

**Head office in Shanghai:**

Room 05-06, 16th Floor, Hongjia Building, No.388 Fushan Rd. (Near Xiangcheng Rd.), Pudong, Shanghai, China.

**Post Code:** 200122

**Tel:** +86-21-58355541,+86-21-58353145,+86-21-58353343

**Fax:** +86-21-58353141

**E-mail:** [trisunseal@yahoo.com.cn](mailto:trisunseal@yahoo.com.cn)