

Oil Pipe Machining Insert

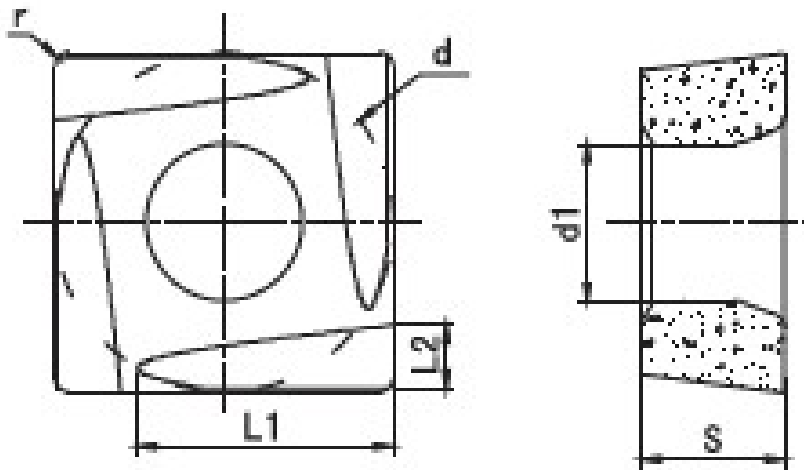
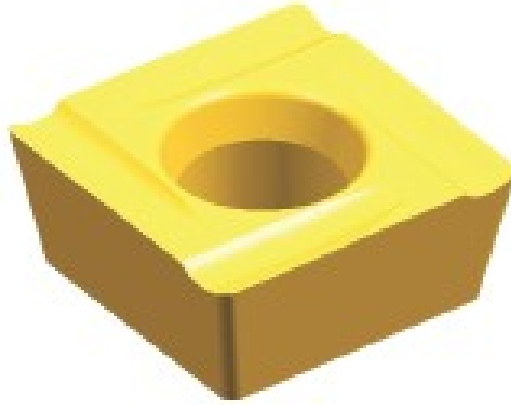

Type	Dimension(mm)						Material grade	
	L1	L2	d	s	d1	r	GG03	GG53
SCEX09T304EL	7.17	1.88	9.525	3.97	4.4	0.4	●	○

Shanghai Trisun Parts Manufacture Co.,Ltd.

Head office in Shanghai:

Room 05-06, 16th Floor, Hongjia Building, No.388 Fushan Rd. (Near Xiangcheng Rd.), Pudong, Shanghai, China.

Post Code: 200122

Tel: +86-21-58355541,+86-21-58353145,+86-21-58353343

Fax: +86-21-58353141

E-mail: trisunseal@yahoo.com.cn