

TSDC-A02 24mm-125mm Cartridge Seal

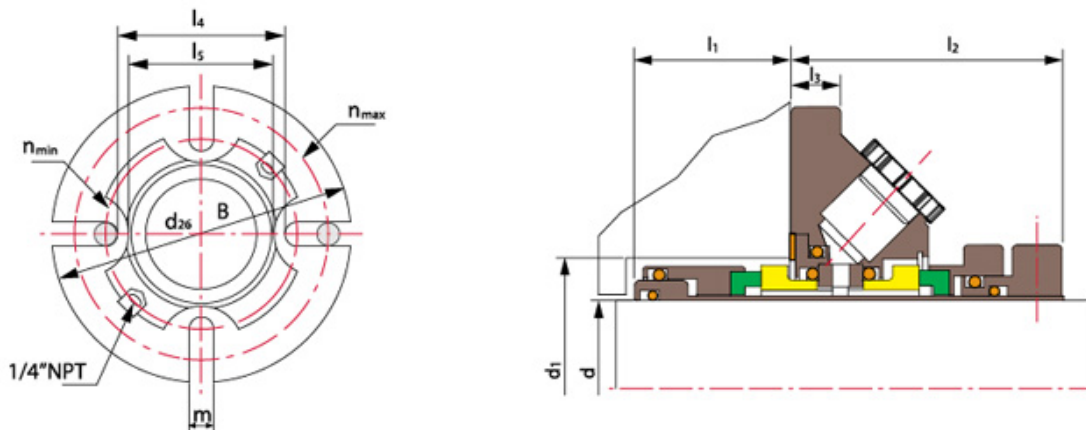

Operating Limits

Pressure: <math>< 2.1\text{MPa}</math> (shaft diameter $\leq 75\text{mm}</math>)
<math>< 1.3\text{MPa}</math> (shaft diameter $> 75\text{mm}</math>)$$

Speed: $\leq 25\text{m/s}</math>$

Temperature: $-30^{\circ}\text{C} \sim +205^{\circ}\text{C}</math>$

Rotary Ring (SiC/Carbon/TC)

Stationary Ring (SiC/TC)

Secondary Seal (VITON/Encapsulated Ring/PTFE)

Other Parts (SUS304/SUS316/Titanium/Hastelloy-C)

Shanghai Trisun Parts Manufacture Co.,Ltd.

Head office in Shanghai:

Room 05-06, 16th Floor, Hongjia Building, No.388 Fushan Rd. (Near Xiangcheng Rd.), Pudong, Shanghai, China.

Post Code: 200122

Tel: +86-21-58355541, +86-21-58353145, +86-21-58353343

Fax: +86-21-58353141

E-mail: trisunseal@yahoo.com.cn

d (inches)	d ₂₆	l ₄	l ₅	l ₃	d ₁		n		m	l ₁	l ₂
					min	max	min	max	max		
1.000	4.125	2.125	1.937	0.519	1.625	1.937	2.687	3.562	1/2	1.281	2.062
1.125	4.250	2.250	2.063	0.519	1.750	2.062	2.812	3.617	1/2	1.281	2.062
1.250	4.375	2.375	2.187	0.519	1.875	2.187	2.937	3.812	1/2	1.281	2.062
1.375	4.375	2.500	2.312	0.519	2.000	2.250	3.062	3.812	1/2	1.281	2.062
1.500	5.000	2.812	2.562	0.644	2.250	2.375	3.375	4.437	1/2	1.312	2.125
1.625	5.000	2.812	2.562	0.644	2.375	2.500	3.375	4.437	1/2	1.312	2.125
1.750	5.500	3.187	2.812	0.644	2.500	2.750	3.750	4.937	1/2	1.312	2.125
1.875	5.500	3.187	2.812	0.644	2.625	2.875	3.750	4.937	1/2	1.312	2.125
2.000	6.000	3.562	3.063	0.644	2.750	3.000	4.125	5.437	1/2	1.380	2.125
2.000-A C	5.250	3.450	3.035	0.644	2.750	3.000	4.000	4.750	1/2	1.380	2.125
2.125	6.000	3.562	3.063	0.644	2.875	3.125	4.125	5.437	1/2	1.380	2.125
2.250	6.500	3.812	3.312	0.644	3.000	3.250	4.500	5.812	5/8	1.380	2.125
3.375	6.500	3.812	3.312	0.644	3.125	3.375	4.500	5.812	5/8	1.380	2.125
2.500	7.000	4.312	3.812	0.769	3.375	3.625	5.000	6.312	5/8	1.500	2.375
2.625	7.000	4.312	3.812	0.769	3.500	3.750	5.000	6.312	5/8	1.500	2.375
2.750	7.000	4.312	3.812	0.769	3.625	3.875	5.000	6.312	5/8	1.500	2.375
2.875	7.500	4.312	4.250	0.769	3.750	4.125	5.625	6.812	5/8	1.500	2.375
3.000	7.500	4.937	4.250	0.769	3.875	4.250	5.625	6.812	5/8	1.500	2.375

Shanghai Trisun Parts Manufacture Co.,Ltd.

Head office in Shanghai:

Room 05-06, 16th Floor, Hongjia Building, No.388 Fushan Rd. (Near Xiangcheng Rd.), Pudong, Shanghai, China.

Post Code: 200122

Tel: +86-21-58355541,+86-21-58353145,+86-21-58353343

Fax: +86-21-58353141

E-mail: trisunseal@yahoo.com.cn

3.125	7.500	4.93 7	4.25 0	0.76 9	4.00 0	4.37 5	5.62 5	6.81 2	5/8	1.50 0	2.37 5
3.250	8.000	5.31 2	4.62 5	0.76 9	4.12 5	4.50 0	6.12 5	7.18 7	3/4	1.50 0	2.37 5
3.375	8.000	5.31 2	4.62 5	0.76 9	4.25 0	4.62 5	6.12 5	7.18 7	3/4	1.50 0	2.37 5
3.500	8.000	5.31 2	4.62 5	0.76 9	4.37 5	4.75 0	6.12 5	7.18 7	3/4	1.50 0	2.37 5
3.625	8.500	5.93 7	5.00 0	0.76 9	4.50 0	5.00 0	6.75 0	7.68 7	3/4	1.50 0	2.37 5
3.750	8.500	5.93 7	5.00 0	0.76 9	4.62 5	5.12 5	6.75 0	7.68 7	3/4	1.50 0	2.37 5
3.875	8.500	5.93 7	5.00 0	0.76 9	4.75 0	5.25 0	6.75 0	7.68 7	3/4	1.50 0	2.37 5
4.000	9.000	6.62 5	5.37 5	0.76 9	4.87 5	5.50 0	7.43 7	8.18 7	3/4	1.50 0	2.37 5
4.125	9.000	6.62 5	5.37 5	0.76 9	5.12 5	5.87 5	7.43 7	8.18 7	3/4	1.50 0	2.37 5
4.250	9.000	6.62 5	5.37 5	0.76 9	5.12 5	5.87 5	7.43 7	8.18 7	3/4	1.50 0	2.37 5
4.375	9.500	7.00 0	5.75 0	0.76 9	5.37 5	6.25 0	7.81 2	8.68 7	3/4	1.50 0	2.37 5
4.500	9.500	7.00 0	5.75 0	0.76 9	5.37 5	6.25 0	7.81 2	8.68 7	3/4	1.50 0	2.37 5
4.625	10.00 0	7.34 5	6.12 5	0.76 9	5.62 5	6.62 5	8.31 2	9.06 2	7/8	1.50 0	2.37 5
4.750	10.00 0	7.34 5	6.12 5	0.76 9	5.62 5	6.62 5	8.31 2	9.06 2	7/8	1.50 0	2.37 5
4.875	10.00 0	7.34 5	6.12 5	0.76 9	5.87 5	6.62 5	8.31 2	9.06 2	7/8	1.50 0	2.37 5
5.000	10.00 0	7.34 5	6.12 5	0.76 9	5.87 5	6.62 5	8.31 2	9.06 2	7/8	1.50 0	2.37 5

Shanghai Trisun Parts Manufacture Co.,Ltd.

Head office in Shanghai:

Room 05-06, 16th Floor, Hongjia Building, No.388 Fushan Rd. (Near Xiangcheng Rd.), Pudong, Shanghai, China.

Post Code: 200122

Tel: +86-21-58355541,+86-21-58353145,+86-21-58353343

Fax: +86-21-58353141

E-mail: trisunseal@yahoo.com.cn