

TSSC-C03 1.750mm-4.750mm

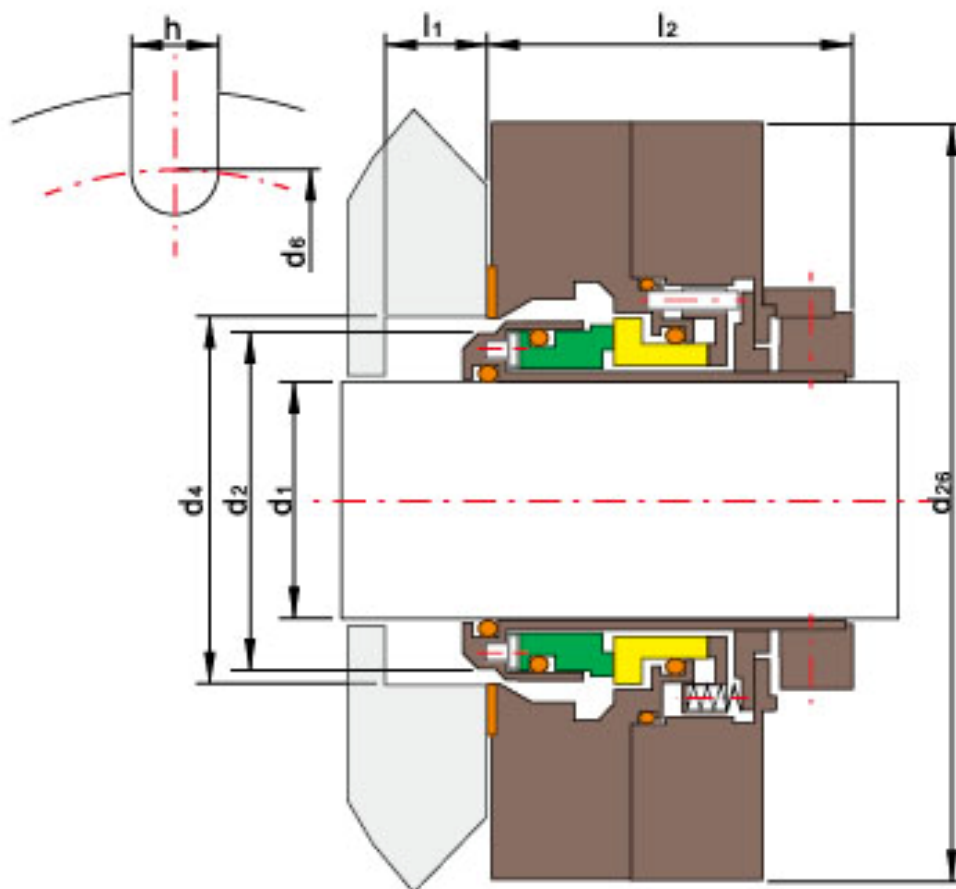
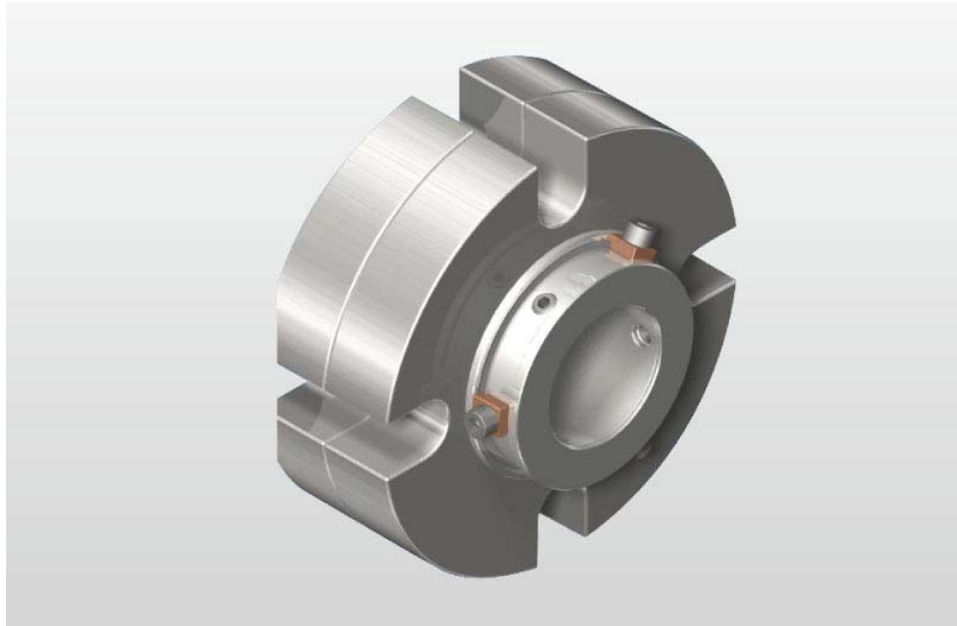

Shanghai Trisun Parts Manufacture Co.,Ltd.

Head office in Shanghai:

Room 05-06, 16th Floor, Hongjia Building, No.388 Fushan Rd. (Near Xiangcheng Rd.), Pudong, Shanghai, China.

Post Code: 200122

Tel: +86-21-58355541,+86-21-58353145,+86-21-58353343

Fax: +86-21-58353141

E-mail: trisunseal@yahoo.com.cn



Features:

Operating Limits:

Pressure: ≤4MPa

Speed: ≤20m/s

Temperature: -40℃~+204℃

- 1.Rotary Ring (SiC/TC)
- 2.Stationary Ring (SiC/Carbon/TC)
3. Secondary Seal (VITON/AFLAS/Kalrez)
- 4.Other Parts (C-276/dUPLE/316)

d ₁	d ₂		d ₄	d ₆	d ₂₆	l ₁	l ₂			h
	min	max					3/8"	1/2"	5/8"	
1.750	2.500	2.810	0.69	0.570	5.490	1.910	3.620	3.75*	-	1.270
1.875	2.630	2.940	0.69	0.570	5.490	1.910	3.750	3.85*	-	1.270
2.000	2.750	3.190	0.69	0.570	5.490	1.910	4.000	4.130	-	1.270
2.125	2.880	3.440	0.69	0.690	5.990	1.910	4.250	4.380	4.500	1.270
2.250	3.000	3.560	0.69	0.690	5.990	1.910	4.370	4.500	4.620	1.270
2.375	3.130	3.590	0.69	0.690	5.990	1.910	4.430	4.560	4.680	1.270
2.500	3.250	3.810	0.69	0.690	6.490	1.910	4.620	4.750	4.870	1.270
2.625	3.630	4.040	0.88	0.690	6.450	2.500	5.020	5.150	-	1.770
2.750	3.750	4.380	0.88	0.690	7.700	2.500	5.420	5.550	-	1.770
2.875	3.880	4.500	0.88	0.690	7.830	2.500	5.500	5.620	-	1.770
3.000	4.000	4.690	0.88	0.690	7.940	2.500	5.650	5.770	-	1.770
3.125	4.130	4.810	0.88	0.690	7.990	2.500	5.800	5.920	-	1.770
3.250	4.250	4.940	0.88	0.690	8.190	2.500	5.930	6.050	-	1.770
3.375	4.380	5.060	0.88	0.810	8.300	2.500	6.020	6.140	6.270	1.770
3.500	4.500	5.190	0.88	0.810	8.440	2.500	6.180	6.310	6.430	1.770
3.625	4.630	5.310	0.88	0.810	8.490	2.500	6.310	6.440	6.560	1.770

Shanghai Trisun Parts Manufacture Co.,Ltd.

Head office in Shanghai:

Room 05-06, 16th Floor, Hongjia Building, No.388 Fushan Rd. (Near Xiangcheng Rd.), Pudong, Shanghai, China.

Post Code: 200122

Tel: +86-21-58355541,+86-21-58353145,+86-21-58353343

Fax: +86-21-58353141

E-mail: trisunseal@yahoo.com.cn

3.750	4.750	5.390	0.88	0.810	8.710	2.500	6.380	6.510	6.630	1.770
3.875	4.880	5.510	0.88	0.810	8.840	2.500	6.520	6.640	6.770	1.770
4.000	5.000	5.690	0.88	0.810	8.960	2.500	6.660	6.780	6.910	1.770
4.125	5.130	5.810	0.88	0.810	8.990	2.500	6.790	6.900	7.030	1.770
4.250	5.250	5.940	0.88	0.810	8.990	2.500	6.910	7.040	7.160	1.770
4.375	5.380	6.060	0.88	0.810	9.330	2.500	7.030	7.150	7.280	1.770
4.500	5.500	6.190	0.88	0.810	9.490	2.500	7.180	7.300	7.430	1.770
4.625	5.630	6.310	0.88	0.810	9.490	2.500	7.280	7.400	7.530	1.770
4.750	5.750	6.470	0.88	0.810	10.490	2.500	7.400	7.530	7.650	1.770

Shanghai Trisun Parts Manufacture Co.,Ltd.

Head office in Shanghai:

Room 05-06, 16th Floor, Hongjia Building, No.388 Fushan Rd. (Near Xiangcheng Rd.), Pudong, Shanghai, China.

Post Code: 200122

Tel: +86-21-58355541,+86-21-58353145,+86-21-58353343

Fax: +86-21-58353141

E-mail: trisunseal@yahoo.com.cn