

## TSDC-A03 24mm-125mm

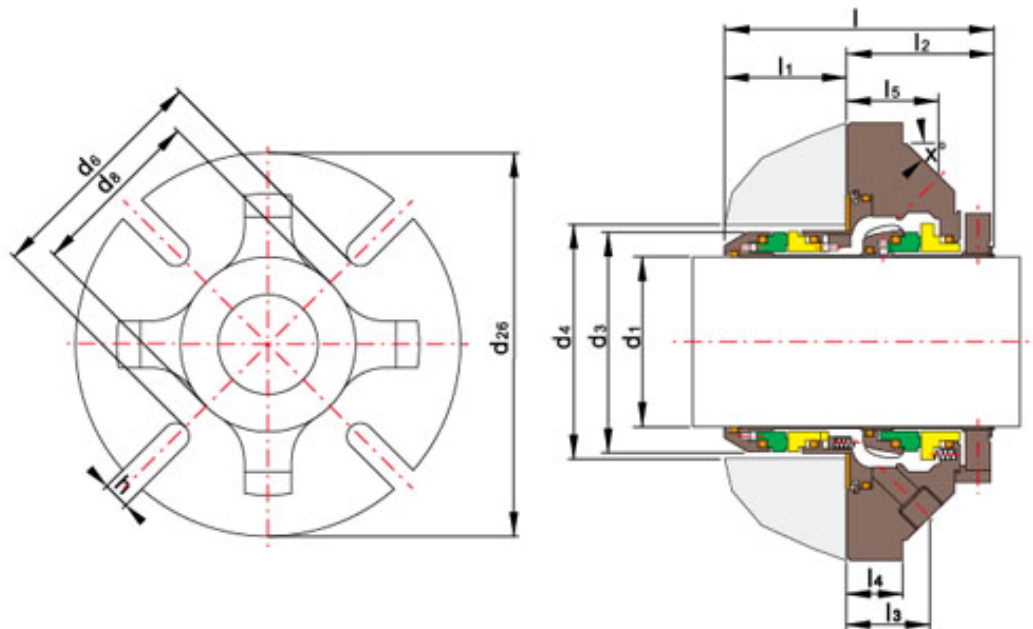
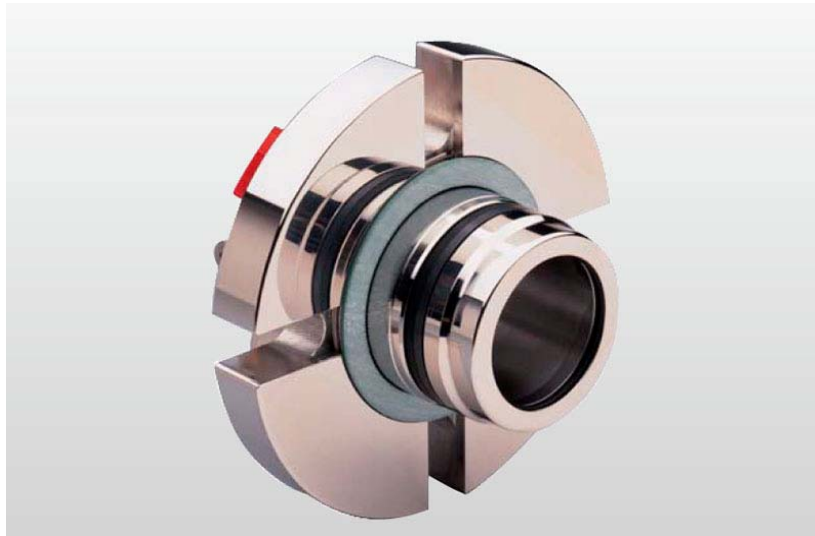

### Features:

#### Operating Limits:

Pressure:  $\leq 2.1\text{MPa}$

Speed:  $\leq 25\text{m/s}$

Temperature:  $-40^\circ\text{C} \sim 204^\circ\text{C}$

1. Rotary Ring (SiC/Carbon/TC)
2. Stationary Ring (SiC/TC)

---

**Shanghai Trisun Parts Manufacture Co.,Ltd.**

#### Head office in Shanghai:

Room 05-06, 16th Floor, Hongjia Building, No.388 Fushan Rd. (Near Xiangcheng Rd.), Pudong, Shanghai, China.

**Post Code:** 200122

**Tel:** +86-21-58355541,+86-21-58353145,+86-21-58353343

**Fax:** +86-21-58353141

**E-mail:** [trisunseal@yahoo.com.cn](mailto:trisunseal@yahoo.com.cn)



3. Secondary Seal (VITON/EPDM/Kalrez)

4. Other Parts (C-276/Duplex/316)

Seal size (mm)	d <sub>1</sub>	d <sub>2</sub>	d <sub>4</sub>		d <sub>6</sub>	d <sub>8</sub>	d <sub>26</sub>	l	l <sub>1</sub>	l <sub>2</sub>	l <sub>3</sub>	l <sub>4</sub>	l <sub>5</sub>	h	x
			min	max											
24	24	40.8	43.0	48.0	57.7	50.4	105.0	92.0	53.1	38.9	28.2	19.2	29.2	14.0	20°
25	25	41.8	44.0	51.0	62.0	51.0	105.0	92.0	53.1	38.9	27.8	19.2	29.2	14.0	20°
28	28	45.4	47.0	54.0	65.0	55.5	111.0	92.0	53.1	38.9	27.5	19.2	29.4	14.0	20°
30	30	46.8	49.0	54.0	64.6	56.4	105.0	92.0	53.1	38.9	27.4	19.2	29.7	14.0	20°
32	32	49.8	51.0	57.0	66.5	59.4	105.0	92.0	53.1	38.9	28.4	21.5	30.9	14.0	25°
33	33	49.8	51.0	57.0	66.5	59.4	105.0	92.0	53.1	38.9	28.4	21.5	30.9	14.0	25°
35	35	51.8	53.0	59.0	68.5	61.4	120.0	92.0	53.1	38.9	29.3	20.7	29.3	14.0	15°
40	40	57.6	59.0	70.5	80.7	70.8	135.0	93.2	53.1	40.1	30.1	21.3	30.1	14.0	20°
43	43	58.6	61.0	70.5	80.7	70.8	135.0	93.2	53.1	40.1	26.7	21.3	29.8	14.0	15°
45	45	62.0	64.0	75.0	84.6	73.8	139.0	93.2	53.1	40.1	30.5	21.9	30.5	14.0	20°
50	50	68.0	70.0	78.0	87.6	78.9	150.0	93.2	53.1	40.1	30.5	21.6	30.5	17.5	20°
53	53	71.6	73.0	87.0	97.0	85.0	150.0	93.2	53.1	40.1	25.7	21.3	29.5	17.5	15°
55	55	71.6	73.0	87.0	97.0	85.0	150.0	93.2	53.1	40.1	25.7	21.3	29.5	17.5	15°
60	60	77.9	80.0	92.0	102.4	88.0	164.5	93.2	53.1	40.1	30.5	21.6	30.5	17.5	20°
63	63	81.1	83.0	98.5	108.7	94.4	171.0	93.2	53.1	40.1	29.8	21.6	29.8	17.5	15°
65	65	84.3	86.0	98.5	108.7	94.4	171.0	93.2	53.1	40.1	29.4	21.3	29.4	17.5	15°
70	70	87.4	89.0	100.0	112.0	98.3	180.5	93.2	53.1	40.1	29.7	21.3	29.7	17.5	20°
75	75	98.0	101.6	117.5	131.4	116.5	189.3	115.9	63.5	52.4	25.0	25.8	36.3	17.5	20°
80	80	104.4	108.0	127.0	142.5	126.0	201.9	115.9	63.5	52.4	25.0	25.8	36.3	21.0	20°
85	85	107.6	111.1	127.0	142.5	126.0	201.9	115.9	63.5	52.4	25.0	25.8	36.3	21.0	20°
90	90	113.9	117.5	136.5	152.0	135.5	214.6	115.9	63.5	52.4	26.2	25.8	36.3	21.0	20°

**Shanghai Trisun Parts Manufacture Co.,Ltd.**

**Head office in Shanghai:**

Room 05-06, 16th Floor, Hongjia Building, No.388 Fushan Rd. (Near Xiangcheng Rd.), Pudong, Shanghai, China.

**Post Code:** 200122

**Tel:** +86-21-58355541,+86-21-58353145,+86-21-58353343

**Fax:** +86-21-58353141

**E-mail:** [trisunseal@yahoo.com.cn](mailto:trisunseal@yahoo.com.cn)



95	95	117.1	120.0	136.5	152.0	135.5	214.6	115.9	63.5	52.4	26.2	25.8	36.3	21.0	20°
100	100	123.4	127.0	139.7	155.2	138.7	227.3	115.9	63.5	52.4	26.2	25.8	36.3	21.0	20°
105	105	129.8	133.4	152.4	167.9	151.4	240.0	115.9	63.5	52.4	36.0	23.8	40.1	21.0	45°
110	110	136.1	139.7	152.4	167.9	151.4	240.0	115.9	63.5	52.4	36.0	23.8	40.1	21.0	45°
115	115	142.5	146.1	165.1	180.6	164.1	252.7	115.9	63.5	52.4	36.0	23.8	40.1	24.0	45°
120	120	142.5	146.1	165.1	180.6	164.1	252.7	115.9	63.5	52.4	36.0	23.8	40.1	24.0	45°
125	125	148.8	152.4	165.1	180.6	164.1	252.7	115.9	63.5	52.4	36.0	23.8	40.1	24.0	45°

---

**Shanghai Trisun Parts Manufacture Co.,Ltd.**

**Head office in Shanghai:**

Room 05-06, 16th Floor, Hongjia Building, No.388 Fushan Rd. (Near Xiangcheng Rd.), Pudong, Shanghai, China.

**Post Code:** 200122

**Tel:** +86-21-58355541,+86-21-58353145,+86-21-58353343

**Fax:** +86-21-58353141

**E-mail:** [trisunseal@yahoo.com.cn](mailto:trisunseal@yahoo.com.cn)