





**Kare Indexable Insert**

SN□□

Profil	Tip	Boyut(mm)					Materyal Sinifi	
		L≈	d	s	d <sub>1</sub>	r	GG90	GG91
	SNMG090304-GM	9.525	9.525	3.18	3.81	0.4	●	○
	SNMG090308-GM					0.8	●	○
	SNMG090312-GM					1.2	●	○
	SNMG120404-GM	12.7	12.7	4.76	5.16	0.4	●	○
	SNMG120408-GM					0.8	●	○
	SNMG120412-GM					1.2	●	○
	SNMG150612-GM	15.875	15.875	6.35	6.35	1.2	●	○
	SNMG150616-GM					1.6	●	○
	SNMG190612-GM	19.05	19.05	6.35	7.94	1.2	●	○
	SNMG190616-GM					1.6	●	○
SNMG190624-GM	2.4					●	○	

Profil	Tip	Boyut(mm)					Materyal Sinifi		
		L≈	d	s	d <sub>1</sub>	r	GG90	GG91	GG71
	SNMG090304-GR1	9.525	9.525	3.18	3.81	0.4	●	○	
	SNMG090308-GR1					0.8	●	○	
	SNMG090312-GR1					1.2	●	○	
	SNMG120404-GR1	12.7	12.7	4.76	5.16	0.4	●	○	
	SNMG120408-GR1					0.8	●	○	
	SNMG120412-GR1					1.2	●	○	
	SNMG150612-GR1	15.875	15.875	6.35	6.35	1.2	●	○	
	SNMG150616-GR1					1.6	●	○	
	SNMG190612-GR1	19.05	19.05	6.35	7.94	1.2	●	○	
	SNMG190616-GR1					1.6	●	○	
SNMG190624-GR1	2.4					●	○		
	SNMG190612-GR2	19.05	19.05	6.35	7.94	1.2	●	○	
	SNMG190616-GR2					1.6	●	○	
	SNMG190624-GR2					2.4	●	○	
	SNMG250724-GR2	25.4	25.4	7.94	9.12	2.4	●	○	
	SNMG250924-GR2					9.52	2.4	●	○
	SNMG090304-GR2	9.525	9.525	3.18	3.81	0.4	●	○	
	SNMG090308-GR2					0.8	●	○	
	SNMG120408-GR2	12.7	12.7	4.76	5.16	0.8	●	○	
	SNMG120412-GR2					1.2	●	○	
	SNMG120416-GR2					1.6	●	○	
	SNMG190608-GR2	19.05	19.05	6.35	7.94	0.8	●	○	
	SNMG190612-GR2					1.2	●	○	
	SNMG190616-GR2					1.6	●	○	
	SNMG250724-GR2	25.4	25.4	7.94	9.12	2.4	●	○	
	SNMG250924-GR2					2.4	●	○	

**Shanghai Trisun Parts Manufacture Co.,Ltd.**

**Şangay Merkez Ofis:**

Room 05-06, 16th Floor, Hongjia Building, No.388 Fushan Rd. (Near Xiangcheng Rd.), Pudong, Shanghai, China.

**Posta Kodu:** 200122

**Tel:** +86-21-58355541,+86-21-58353145,+86-21-58353343

**Fax:** +86-21-58353141

**E-mail:** [trisun24@trisunltd.com](mailto:trisun24@trisunltd.com)

SNMM150616-GR	15.875	15.875	6.35	6.35	1.6	●	○	
SNMM190616-GR	19.05	19.05	6.35	6.35	1.6	●	○	
SNMM250916-GR	25.4	25.4	9.52	9.12	1.6	●	○	
SNMM250924-GR					2.4	●	○	
SNMM090304	9.525	9.525	3.18	3.81	0.4	●	○	
SNMM090308					0.8	●	○	
SNMM090312					1.2	●	○	
SNMM120408	12.7	12.7	4.76	5.16	0.8	●	○	
SNMM120412					1.2	●	○	
SNMM190608	19.05	19.05	6.35	6.35	0.8	●	○	
SNMM190612					1.2	●	○	
SNMM190624					2.4	●	○	
SNMM250724	25.4	25.4	7.94	9.12	2.4	●	○	
SNMM250724-F	25.4	25.4	7.94	9.12	2.4	●	○	
SNMM250924-F					2.4	●	○	
SNMA090304	9.525	9.525	3.18	3.81	0.4		○	●
SNMA090308					0.8		○	●
SNMA120408	12.7	12.7	4.76	5.16	0.8		○	●
SNMA120412					1.2		○	●
SNMA120416					1.6		○	●
SNMA150616	15.875	15.875	6.35	6.35	1.6		○	●
SNMA190608	19.05	19.05	6.35	7.94	0.8		○	●
SNMA190612					1.2		○	●
SNMA190616					1.6		○	●

SN□□

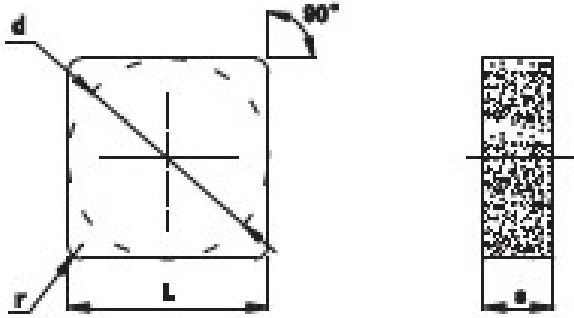

Profil	Tip	Boyut(mm)					Materyal Sinifi	
		L≈	d	s	d <sub>1</sub>	r	GG53	GG83
	SNGN090308	9.525	9.525	3.18		0.8	○	●
	SNGN120408	12.7	12.7	4.76		0.8	○	●
	SNGN150408	15.875	15.875	4.76		0.8	○	●
	SNGN190412	19.05	19.05	4.76		1.2	○	●
	SNUM090304	9.525	9.525	3.18		0.4	○	●
	SNUM090308					0.8	○	●
	SNUM120408	12.7	12.7	4.76		0.8	○	●
	SNUM120412					1.2	○	●
	SNUM150408	15.875	15.875	4.76		0.8	○	●
	SNUM150412					1.2	○	●
	SNUM190412	19.05	19.05	4.76		1.2	○	●
	SNUM190424					2.4	○	●
	SNUM250724	25.4	25.4	7.94		2.4	○	●
	SNUM250924	25.4	25.4	9.52		2.4	○	●

SC□□

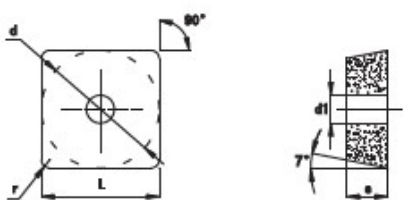

**Shanghai Trisun Parts Manufacture Co.,Ltd.**

**Şangay Merkez Ofis:**

Room 05-06, 16th Floor, Hongjia Building, No.388 Fushan Rd. (Near Xiangcheng Rd.), Pudong, Shanghai, China.

**Posta Kodu:** 200122

**Tel:** +86-21-58355541,+86-21-58353145,+86-21-58353343

**Fax:** +86-21-58353141

**E-mail:** [trisun24@trisunltd.com](mailto:trisun24@trisunltd.com)