

TSMB-A04 1.000-4.000(inç) Metal Körüklü Salmastra

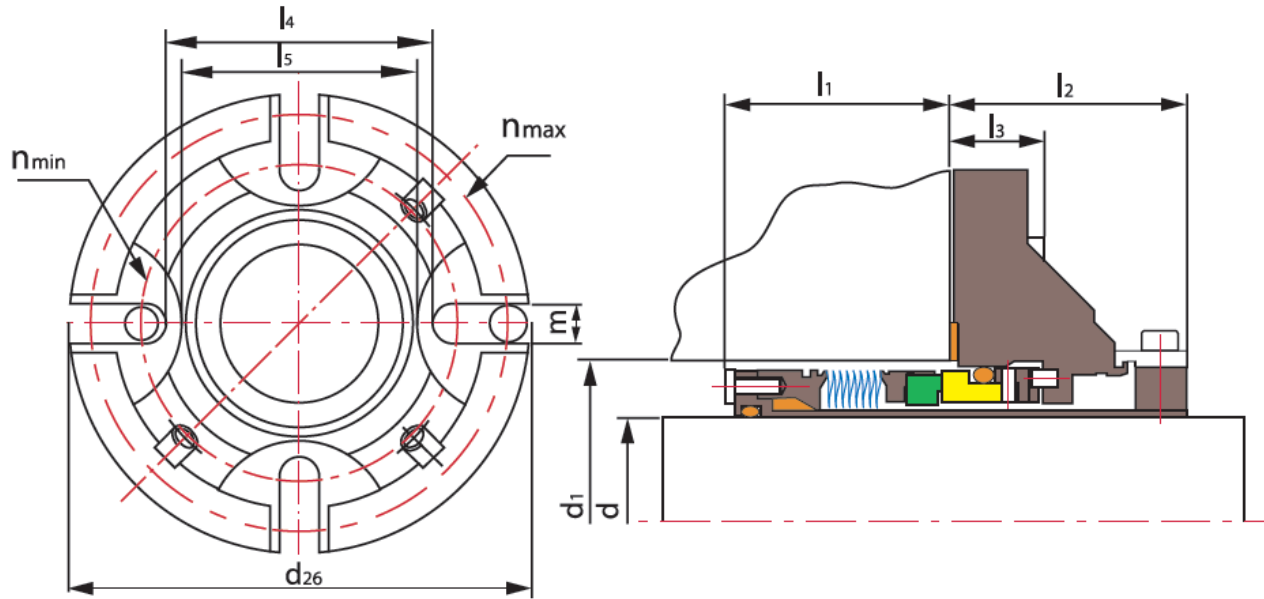

Çalışma Sınırları

Basınç: $\leq 2\text{MPa}$

Hız: $\leq 20\text{m/s}$

Isı: $-30^{\circ}\text{C} \sim +204^{\circ}\text{C}$

Shanghai Trisun Parts Manufacture Co.,Ltd.

Şangay Merkez Ofis:

Room 05-06, 16th Floor, Hongjia Building, No.388 Fushan Rd. (Near Xiangcheng Rd.), Pudong, Shanghai, China.

Posta Kodu: 200122

Tel: +86-21-58355541,+86-21-58353145,+86-21-58353343

Fax: +86-21-58353141

E-mail: trisun24@trisunltd.com

Devir Halkası (SiC/Karbon/TC)

Sabit Halka (SiC/TC)

İkincil Salmastra (VITON/Kapsüllü Halka/PTFE/Esnek Karbon)

Metal Körük (SUS316L/AM350/Inconel718/Titanyum/Hastelloy-C/Alaşım-20)

Diğer Parçalar (SUS304/SUS316/Titanyum/Hastelloy-C)

d (inc)	d ₂₆	l ₄	l ₅	l ₃	d ₁		n		m	l ₁	l ₂
					min	max	min	max			
1.000	4.125	2.125	1.937	0.519	1.625	1.937	2.687	3.562	1/2	1.531	1.590
1.125	4.250	2.250	2.063	0.519	1.750	2.062	2.812	3.687	1/2	1.531	1.590
1.250	4.375	2.375	2.187	1.519	1.875	2.187	2.937	3.812	1/2	1.531	1.590
1.375	4.375	2.500	2.312	0.519	2.000	2.250	3.062	3.812	1/2	1.531	1.590
1.500	5.000	2.812	2.562	0.644	2.250	2.375	3.375	4.437	1/2	1.687	1.752
1.625	5.000	2.812	2.562	0.644	2.375	2.500	3.375	4.437	1/2	1.687	1.752
1.750	5.500	3.187	2.812	0.644	2.500	2.750	3.750	4.937	1/2	1.687	1.752
1.875	5.500	3.187	2.812	0.644	2.625	2.875	3.750	4.937	1/2	1.687	1.752
2.000	6.000	3.562	3.063	0.644	2.750	3.000	4.125	5.437	1/2	1.750	1.752
2.000-AC	5.250	3.450	3.035	0.644	2.750	3.000	4.000	4.750	1/2	1.750	1.752
2.125	6.000	3.562	3.063	0.644	2.875	3.125	4.125	5.437	1/2	1.750	1.752
2.250	6.500	3.812	3.312	0.644	3.000	3.250	4.500	5.812	5/8	1.750	1.752
2.375	6.500	3.812	3.312	0.644	3.125	3.375	4.500	5.812	5/8	1.750	1.752
2.500	7.000	4.312	3.812	0.769	3.375	3.625	5.000	6.312	5/8	2.031	1.877
2.625	7.000	4.312	3.812	0.769	3.500	3.750	5.000	6.312	5/8	2.031	1.877
2.750	7.000	4.312	3.812	0.769	3.625	3.875	5.000	6.312	5/8	2.031	1.877
2.875	7.500	4.937	4.250	0.769	3.750	4.125	5.625	6.812	5/8	2.031	1.877
3.000	7.500	4.937	4.250	0.769	3.875	4.250	5.625	6.812	5/8	2.150	1.877
3.125	7.500	4.937	4.250	0.769	4.000	4.375	5.625	6.812	5/8	2.150	1.877
3.250	8.000	5.312	4.625	0.769	4.125	4.500	6.125	7.187	3/4	2.150	1.877
3.375	8.000	5.312	4.625	0.769	4.250	4.625	6.125	7.187	3/4	2.150	1.877
3.500	8.000	5.312	4.625	0.769	4.375	4.750	6.125	7.187	3/4	2.150	1.877
3.625	8.500	5.937	5.000	0.769	4.500	5.000	6.750	7.687	3/4	2.150	1.877
3.750	8.500	7.937	5.000	0.769	4.625	5.125	6.750	7.687	3/4	2.150	1.877
3.875	9.000	6.625	5.375	0.769	4.875	5.500	7.437	8.187	3/4	2.150	1.877
4.000	9.000	6.625	5.375	0.769	4.875	5.500	7.437	8.187	3/4	2.150	1.877

Shanghai Trisun Parts Manufacture Co.,Ltd.

Şangay Merkez Ofis:

Room 05-06, 16th Floor, Hongjia Building, No.388 Fushan Rd. (Near Xiangcheng Rd.), Pudong, Shanghai, China.

Posta Kodu: 200122

Tel: +86-21-58355541,+86-21-58353145,+86-21-58353343

Fax: +86-21-58353141

E-mail: trisun24@trisunltd.com